

1. Abstract

1. Abstract	1
2. Introduction.	3
3. The comparison of the loads	3
3.1 The comparison of the flight envelopes	3
3.2 Comparison of the wing load	7
3.2.1 Comparison of Ty course	7
3.2.2 Comparison of Tx course	10
3.2.3 Comparison of Moy course	13
3.2.4 Comparison of Mox course	17
3.2.5 Comparison of Mky course	20
3.3 Comparison of tail surfaces	23
3.3.1 Horizontal tail unit (HTU)	23
3.3.1.1 Manouever on HTU	23
3.3.1.2 Gust on HTU	23
3.3.2 Vertical tail unit (VTU)	24
3.3.2.1 Manouevre on VTU	24
3.3.2.2 Gust on HTU	24
3.3.3 Add moment from T configuration of tail unit - HTU on VTU	25
3.3.3.1 Manoeuvre	25
3.3.3.2 Gust	25
4. Strength check of the critical points of the structure.	26
4.1 HTU and rudder VTU.	26
4.2 Control system.	27
4.3 Engine mount and attachment.	27
4.4 Landing gear mount.	27
4.4.1 Description of the landing gear of the airplane	27
4.4.1.1 Main landing gear	27
4.4.1.2 Nosewheel leg	28
4.4.2 Configuration of the weight	28
4.4.3 Falling speed at landing	28
4.4.4 Loads of landing gear.	28
4.4.4.1 UNDERFOOT LOAD	28
4.4.5 BASIC CONDITIONS FOR LANDING	30
4.4.6 Horizontal landing	31
4.4.7 Landing with a big angle of attack	31
4.4.8 Multiple in CG at taxi.	33
4.4.9 Additional conditions for load of landing gear:	33
4.4.9.1 Sideward load	33
4.4.9.2 Braking at taxi	35
4.4.9.3 Additional conditions for the nose gear	35
4.4.10 Check of landing gear	36
4.5 Fuselage of aircraft.	41
4.6 Wing of aircraft.	41
4.6.1 Check of . flange plate of the spar	41
4.6.2 The calculation of the axis of resilience	44
4.6.3 Calculation of the shear flow, check of spar web and covering.	46

4.6.4	Root rib and field joint wing = fuselage.	51
4.6.5	Flapperon and suspension of flapperon.	53
5.	Summary.	53

2. Introduction.

The check was provided for the customers need, who demand the increase of MTOW to 520 kg for possibility the enhancement of the fuel reserve or the weight of luggage. Here was provided the complete calculation on this MTOW. Below is the abstract of critical cases. The others are in the archival database at VANESSA AIR.

Here were done the checks of the critical points of structure, if the loads are increased. This points were chosen under the previous calculations and tests of airplanes UFM-13 and UFM-11.

We postulate the airplane UFM-13 with prime wing and with the ROTAX 912 engine.

Whole new proof uses the method of comparison with existing strength tests, which reports are stated in enclosure.

3. The comparison of the loads

3.1 The comparison of the flight envelopes

By the reason that the JAR-VLA regulations according which have to be provided the type certification for the MTOW 520 kg have the different method of the calculation of the speed in precipitate fly v_D , was this changed and the flight envelope was convert according JAR-VLA.

The comparison of the prime flight envelope and new one is in following and the comparison of the loads under JAR-VLA with the tests, which were done too.

The flight envelope of UFM-13

Manoeuvre envelope

point	n	v	CLlet	q
	[1]	[km/h]	[1]	[Pa]
	0	66.779	0.000	210.756
vs	1	66.779	1.722	210.756
	1.5	81.787	1.722	316.131
	2	94.439	1.722	421.508
	2.5	105.586	1.722	526.885
	3	115.664	1.722	632.262
	3.5	124.931	1.722	737.639
A	3.8	130.175	1.722	800.865
D	3.8	210.000	0.662	2084.201
	0	210.000	0.000	2084.201
E	-1.5	210.000	-0.261	2084.201
G	-1.5	119.991	-0.800	680.450
	-1.4	115.922	-0.800	635.087
	-1.3	111.705	-0.800	589.724
	-1.2	107.323	-0.800	544.360
	-1.1	102.754	-0.800	498.997
	-1	97.972	-0.800	453.634
	0	97.972	0.000	453.634

Gust envelope

point	n	v	CLlet	q
	[1]	[km/h]	[1]	[Pa]
C	1.000	0.000	-	-
u=15.24	4.695	150.000	1.602	1063.368
	1.000	0.000	-	-
u=7.62	3.587	210.000	0.625	2084.201
	1.000	0.000	-	-
u=-7.62	-1.587	210.000	-0.276	2084.201
	1.000	0.000	-	-
u=-15.24	-2.695	150.000	-0.920	1063.368

Flight envelope of JAR-VLA UFM - 13 – 520 kg

Manoeuvre envelope

point	n	v	CLlet	q
	[1]	[km/h]	[1]	[Pa]
	0	72	0.000	245.503
vs	1	72	1.708	245.503
	1.5	88	1.708	368.251
	2	102	1.708	491.001
	2.5	114	1.708	613.751
	3	125	1.708	736.501
	3.5	135	1.708	859.251
A	3.8	140	1.708	932.902
D	3.8	221	0.689	2311.740
	0	221	0.000	2311.740
F	-1.5	177	-0.425	1479.514
G	-1.5	129	-0.800	786.298
	-1.4	125	-0.800	733.878
	-1.3	120	-0.800	681.458
	-1.2	115	-0.800	629.039
	-1.1	110	-0.800	576.619
	-1	105	-0.800	524.199
	0	105	0.000	524.199

Gust envelope

point	n	v	CLlet	q
	[1]	[km/h]	[1]	[Pa]
C	1.000	0	-	-
u=15.24	4.953	177	1.404	1479.514
	1.000	0	-	-
u=7.62	3.470	221	0.630	2311.740
	1.000	0	-	-
u=-7.62	-1.470	221	-0.267	2311.740
	1.000	0	-	-
u=-15.24	-2.953	177	-0.837	1479.514

Comparison of the flight envelopes of UFM-

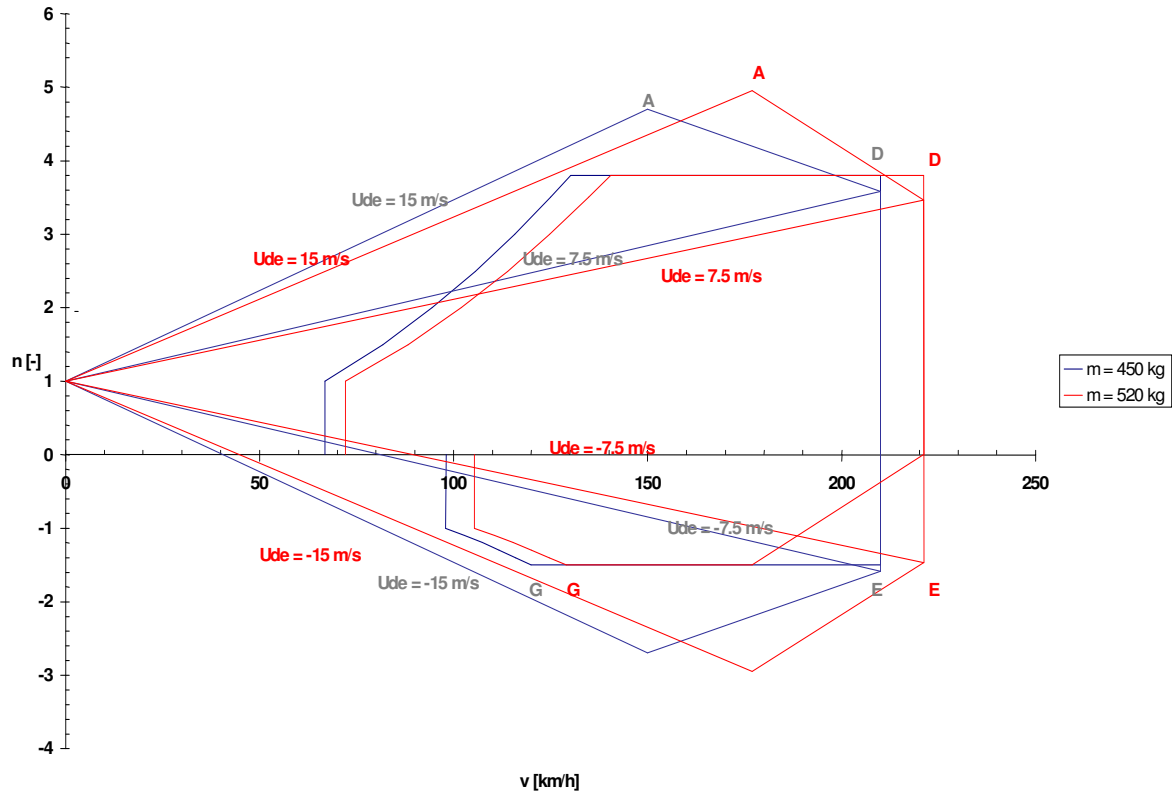

3.2 Comparison of the wing load

3.2.1 Comparison of Ty course

z	A	C	D	let stř.	-7.62	-15.24	G	Va 10st
[m]	[N]	[N]	[N]	[N]	[N]	[N]	[N]	[N]
6.5000	0.0000	0.0000	0.0000	0.0000	0.0000	0.0000	0.0000	0.0000
6.2000	86.7182	114.2816	89.7343	4.7089	-27.8416	-61.7390	-31.3454	10.3936
5.9000	313.4201	415.2752	328.6986	17.7617	-101.476	-225.0091	-114.225	64.5429
5.7540	438.5747	581.4769	460.6876	24.9788	-142.140	-315.1728	-159.995	98.4450
5.6000	578.8671	767.8000	608.6781	33.0750	-187.730	-416.2578	-211.308	138.8778
5.3000	875.8790	1162.352	922.1616	50.2451	-284.281	-630.3385	-319.980	232.3572
5.0000	1198.914	1591.545	1263.250	68.9431	-389.319	-863.2359	-438.203	344.3308
4.7000	1543.875	2049.905	1627.563	88.9226	-501.500	-1111.971	-564.466	474.3791
4.4000	1908.262	2534.095	2012.426	110.0331	-620.005	-1374.729	-697.847	622.5834
4.1000	2290.243	3041.669	2415.883	132.1647	-744.234	-1650.179	-837.670	789.1112
3.8000	2688.224	3570.499	2836.228	155.2214	-873.665	-1937.161	-983.347	974.0619
3.5000	3100.504	4118.312	3271.642	179.1008	-1007.74	-2234.440	-1134.25	1177.311
3.3540	3305.741	4391.008	3488.376	190.9850	-1074.47	-2382.42	-1209.36	1282.685
3.2000	3524.959	4682.283	3719.878	203.6793	-1145.76	-2540.48	-1289.60	1398.284
2.9000	3958.593	5258.479	4177.863	228.7987	-1286.78	-2853.16	-1448.32	1636.058
2.6000	4399.488	5844.349	4643.567	254.3474	-1430.18	-3171.10	-1609.72	1889.565
2.3000	4846.427	6438.267	5115.689	280.2520	-1575.54	-3493.424	-1773.33	2157.977
2.0000	5298.499	7039.018	5593.256	306.4579	-1722.58	-3819.450	-1938.83	2440.485
1.7000		7645.71	6075.560	332.9252	-1871.08	-4148.70	-2105.96	2736.143
1.4000	6215.476	8257.590	6561.979	359.6191	-2020.84	-4480.77	-2274.53	3043.486
1.1000	6679.165	8873.787	7051.834	386.5012	-2171.66	-4815.18	-2444.28	3360.281
0.8000	7145.471	9493.456	7544.443	413.5332	-2323.34	-5151.476	-2614.99	3682.905
0.5000	7613.931	10115.97	8039.311	440.6873	-2475.70	-5489.31	-2786.48	4001.333
0.2000	8085.651	10742.83	8537.621	468.0300	-2629.13	-5829.507	-2959.17	4307.598
0.0000	8402.450	11163.82	8872.283	486.3938	-2732.17	-6057.976	-3075.14	4506.497

Va +5 f -5	Vd 3.5st	Vd 1.5 f -5	Va -20 st	Va -25 f -5	Vd -6.5 st	Vd -8 f -5	Flap
[N]	[N]	[N]	[N]	[N]	[N]	[N]	[N]
0.0000	0.0000	0.0000	0.0000	0.0000	0.0000	0.0000	0.0000
-0.3150	15.4962	5.4594	82.6701	71.9614	85.6566	75.6198	51.3376
28.7392	83.2481	49.6907	281.3808	245.5771	293.7376	260.1803	185.7976
48.1813	124.5934	77.4833	385.1582	334.8946	402.9125	355.8024	260.1438
72.2998	173.3137	110.9128	498.7077	432.1297	522.6088	460.2079	343.4994
131.2046	284.1716	189.3652	731.4286	630.2760	768.6315	673.8251	520.1265
205.5545	414.7936	284.7240	974.4012	835.6248	1026.4171	896.3475	712.3410
295.4007	564.4762	396.7269	1223.4389	1044.4606	1291.6055	1123.8561	917.6658
401.1514	733.1144	525.5749	1475.7533	1254.3214	1561.3057	1353.7662	1134.5740
523.2164	920.7358	671.5231	1729.2028	1463.3080	1833.3039	1584.0912	1361.9463
661.9091	1127.3193	834.7508	1981.9789	1669.8261	2105.7271	1813.1586	1598.8076
817.3407	1352.6187	1015.2320	2232.3997	1872.4287	2376.8165	2039.4298	1844.1155
898.9281	1468.8389	1109.1580	2352.8938	1969.1362	2507.7140	2148.0331	1966.2146
989.1787	1595.9290	1212.4904	2478.6923	2069.5866	2644.7054	2261.2667	2096.6043
1177.0920	1856.1583	1425.9876	2719.1337	2260.1677	2907.5244	2477.3536	2354.4151
1380.1516	2132.1472	1654.6935	2952.4784	2443.0643	3163.9405	2686.4867	2616.4470
1597.6899	2423.0003	1897.8647	3178.2491	2617.9613	3413.4008	2888.2650	2881.9563
1829.2061	2727.8494	2154.9211	3396.7176	2785.4379	3656.0851	3083.1567	3150.2962
2074.1709	3045.6963	2425.2561	3608.8922	2946.9201	3892.8935	3272.4531	3420.8988
2331.4046	3375.0591	2707.6533	3816.0967	3104.0152	4125.0495	3457.6436	3693.3070
2598.9767	3713.7031	3000.1621	4020.3972	3259.0922	4354.4920	3640.9509	3967.0256
2874.5250	4057.9565	3300.2930	4227.4953	3419.1144	4586.6016	3828.9380	4241.0819
3152.6880	4397.6334	3602.2318	4457.7268	3609.0816	4840.6649	4045.2632	4512.9123
3428.1276	4724.8312	3900.5376	4726.7550	3847.2837	5131.7153	4307.4216	4781.8167
3609.5158	4937.6965	4096.9913	4921.7144	4024.7330	5340.7571	4500.0518	4960.8291

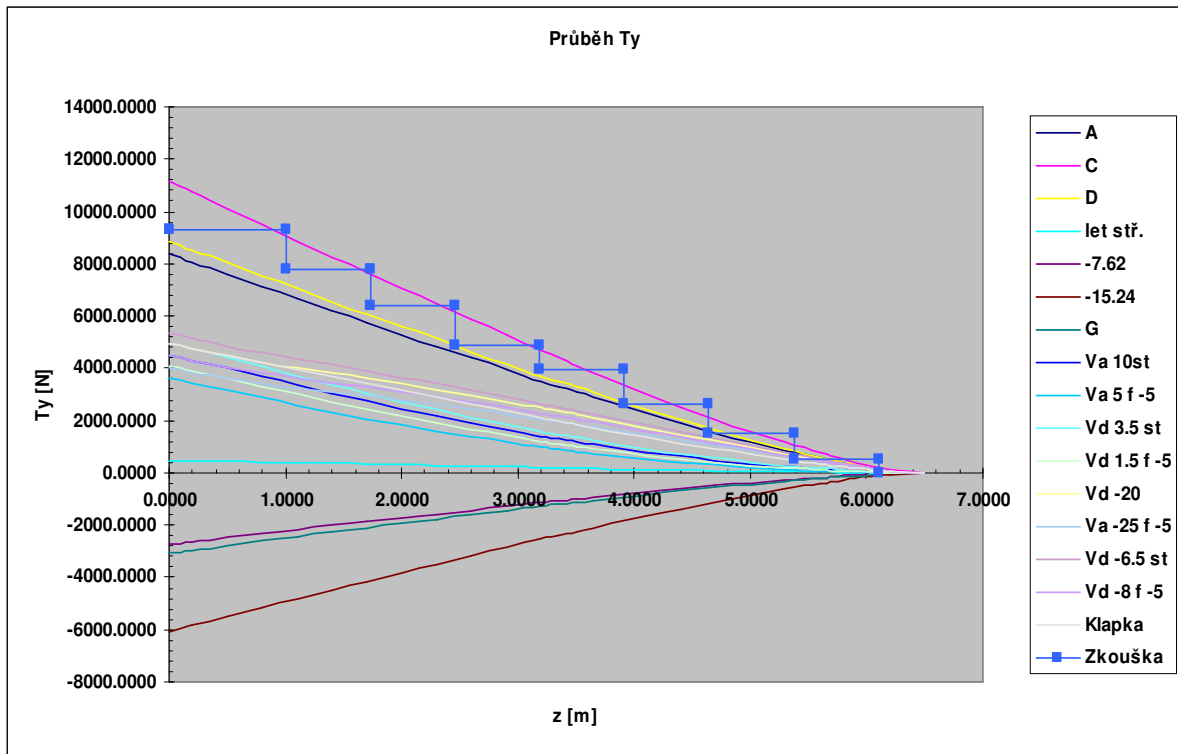

3.2.2 Comparison of Tx course

z	A	C	D	let stř.	-7.62	-15.24	G	Va 10st
[m]	[N]	[N]	[N]	[N]	[N]	[N]	[N]	[N]
6.5000	0.0000	0.0000	0.0000	0.0000	0.0000	0.0000	0.0000	0.0000
6.2000	3.8763	4.3222	-2.9111	-7.0440	0.2639	10.0553	4.7904	-5.0445
5.9000	36.8087	38.2858	-0.4884	-15.7404	5.9016	43.0839	20.8716	-5.6520
5.7540	55.3264	57.3709	0.9974	-20.3977	9.0871	61.4175	29.8021	-5.3586
5.6000	76.2770	78.9563	2.7478	-25.5361	12.6998	82.0257	39.8428	-4.6529
5.3000	121.5383	125.5563	6.8529	-36.0279	20.5450	125.9235	61.2417	-1.8233
5.0000	171.4873	176.9571	11.6353	-47.1312	29.2344	173.8809	84.6281	2.8123
4.7000	225.2060	232.2238	16.9093	-58.8263	38.5958	225.2056	109.6610	9.2022
4.4000	282.1348	290.7866	22.5618	-71.1012	48.5246	279.4752	136.1325	17.3565
4.1000	341.8634	352.2279	28.5096	-83.9470	58.9438	336.3804	163.8902	27.2957
3.8000	404.0347	416.1840	34.6806	-97.3561	69.7867	395.6516	192.8013	39.0321
3.5000	468.2680	482.2672	40.9976	111.3202	80.9819	457.0016	222.7243	52.5504
3.3540	500.1442	515.0649	44.0984	118.3142	86.5333	487.5127	237.6047	59.7541
3.2000	534.2070	550.1119	47.4171	125.7782	92.4661	520.1068	253.5012	67.8285
2.9000	601.8638	619.7139	54.1039	140.4243	104.2621	584.6630	284.9891	85.0310
2.6000	670.9174	690.7437	61.0187	155.2033	116.3128	650.3781	317.0455	104.0712
2.3000	741.0948	762.9233	68.1064	170.1092	128.5673	717.0465	349.5690	124.8470
2.0000	812.1925	836.0455	75.3257	185.1377	140.9872	784.5144	382.4839	147.2593
1.7000	884.0620	909.9592	82.6467	200.2855	153.5449	852.6698	415.7350	171.1919
1.4000	956.5733	984.5319	90.0429	215.5500	166.2159	921.4148	449.2740	196.4653
1.1000	1029.584	1059.618	97.4856	230.9280	178.9737	990.6418	483.0481	222.8053
0.8000	1102.951	1135.074	104.9459	246.4164	191.7914	1060.243	517.0042	249.7673
0.5000	1176.571	1210.792	112.4028	262.0130	204.6497	1130.140	551.1037	276.1210
0.2000	1250.692	1287.026	119.9064	277.7232	217.5949	1200.520	585.4386	300.8888
0.0000	1300.498	1338.250	124.9579	288.2622	226.2947	1247.795	608.5017	316.7012

Va +5 f -5	Vd 3.5st	Vd 1.5 f -5	Va -20 st	Va -25 f -5	Vd -6.5 st	Vd -8 f -5	flap
[N]	[N]	[N]	[N]	[N]	[N]	[N]	[N]
0.0000	0.0000	0.0000	0.0000	0.0000	0.0000	0.0000	0.0000
-6.3586	-4.2294	-4.2453	3.8251	2.5109	-4.1182	-4.1341	1.6845
-10.0457	-9.0037	-9.0569	20.9577	16.5640	-8.6701	-8.7233	20.7906
-11.5268	-11.5410	-11.6156	29.8260	23.6578	-11.0999	-11.1746	31.5810
-12.8232	-14.3286	-14.4274	39.5043	31.3341	-13.7750	-13.8739	43.8045
-14.2364	-19.9697	-20.1199	59.4213	47.0082	-19.2019	-19.3522	70.3009
-14.2180	-25.8916	-26.0977	80.1327	63.1024	-24.9223	-25.1284	99.6079
-12.7615	-32.0953	-32.3612	101.1247	79.1609	-30.9430	-31.2089	131.1625
-9.8170	-38.5812	-38.9101	122.0551	94.8816	-37.2687	-37.5976	164.6176
-5.3341	-45.3491	-45.7440	142.6611	110.0312	-43.9029	-44.2978	199.7188
0.7256	-52.3990	-52.8626	162.7207	124.4142	-50.8484	-51.3121	236.2443
8.3757	-59.7313	-60.2660	182.0277	137.8531	-58.1082	-58.6429	273.9573
12.6604	-63.4023	-63.9723	191.0869	143.9933	-61.7559	-62.3259	292.6632
17.6242	-67.3145	-67.9222	200.4130	150.2087	-65.6525	-66.2601	312.6469
28.7081	-74.9633	-75.6450	217.9430	161.6200	-73.2972	-73.9789	352.3293
41.5573	-82.6500	-83.4066	234.5087	171.9949	-81.0148	-81.7715	392.8238
56.0900	-90.3758	-91.2080	250.0517	181.2948	-88.8063	-89.6385	433.9613
72.2448	-98.1424	-99.0503	264.6053	189.5908	-96.6713	-97.5793	475.5949
89.9566	-105.951	-106.9343	278.2932	197.0579	-	-105.5917	517.5953
109.0807	-	-	-	-	-	-	-
	113.804	-	-	-	-	-	-
	4	-114.8620	291.2778	203.8932	112.6158	-113.6735	559.8588
129.3802	-	-	-	-	-	-	-
	121.705	-	-	-	-	-	-
	8	-122.8365	303.8128	210.3876	120.6903	-121.8211	602.2727
150.5651	-	-	-	-	-	-	-
	129.661	-	-	-	-	-	-
	1	-130.8618	316.5978	217.3956	128.8233	-130.0240	644.6159
171.9777	-	-	-	-	-	-	-
	137.686	-	-	-	-	-	-
	5	-138.9470	332.1283	227.9850	136.9844	-138.2449	686.3057
192.9627	-	-	-	-	-	-	-
	145.794	-	-	-	-	-	-
	4	-147.1007	352.3265	244.4003	145.1496	-146.4559	727.1830
206.6262	-	-	-	-	-	-	-
	151.242	-	-	-	-	-	-
	9	-152.5752	367.6555	257.5805	150.6042	-151.9365	754.2942

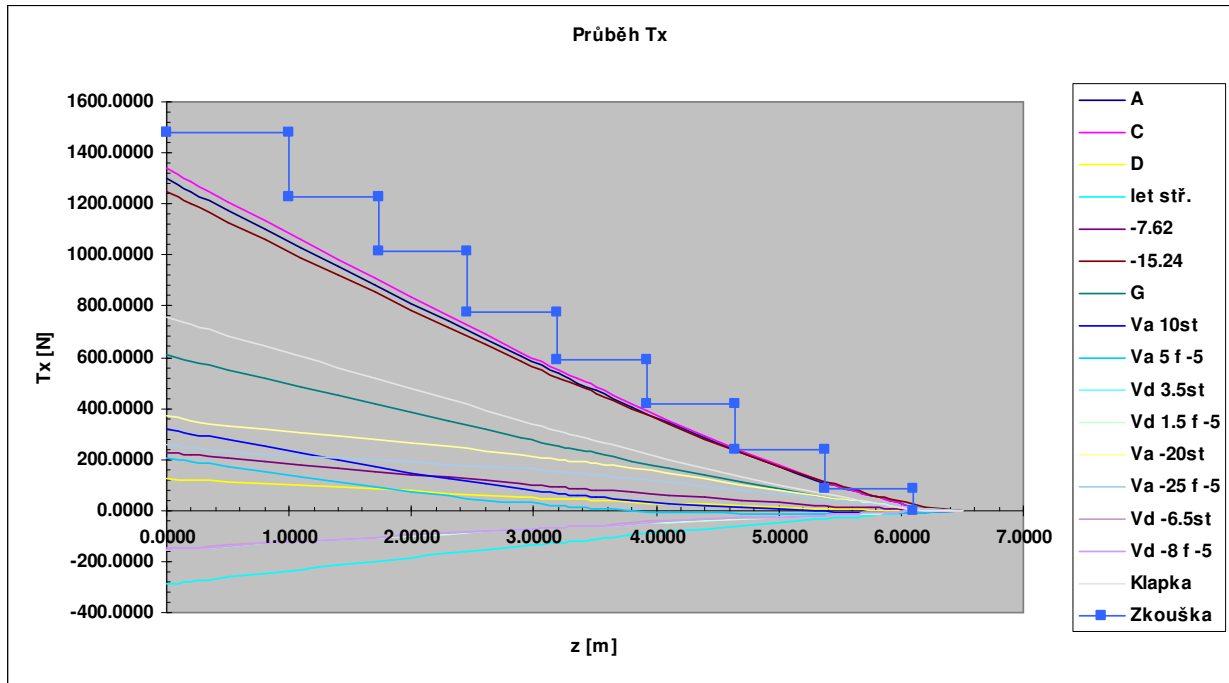

3.2.3 Comparison of Moy course

z	A	C	D	let stř.	-7.62	-15.24	G	Va 10st
[m]	[Nm]	[Nm]	[Nm]	[Nm]	[Nm]	[Nm]	[Nm]	[Nm]
6.5000	0.0000	0.0000	0.0000	0.0000	0.0000	0.0000	0.0000	0.0000
6.2000	13.0077	17.1422	13.4601	0.7063	-4.1762	-9.2608	-4.7018	1.5590
5.9000	73.0285	96.5758	76.2251	4.0769	-23.5739	-52.2731	-26.5375	12.7995
5.7540	127.9241	169.3387	133.8503	7.1970	-41.3580	-91.7063	-46.5556	24.6976
5.6000	206.2671	273.2330	216.1914	11.6671	-66.7580	-148.0265	-75.1459	42.9715
5.3000	424.4790	562.7558	445.8174	24.1651	-	-	-	-
5.0000	735.6981	975.8404	773.6293	42.0434	238.5998	-529.0521	268.5667	185.1599
4.7000	1147.1166	1522.0580	1207.2514	65.7232	372.2227	-825.3332	418.9672	307.9664
4.4000	1664.9373	2209.6581	1753.2499	95.5666	540.4486	-1198.3384	608.3142	472.5108
4.1000	2294.7131	3046.0230	2417.4965	131.8963	745.0847	-1652.0747	838.6418	684.2650
3.8000	3041.4832	4037.8483	3205.3132	175.0042	987.7697	-2190.1757	1111.7945	948.7410
3.5000	3909.7925	5191.1700	4121.4938	225.1525	1269.9805	-2815.9160	1429.4345	1271.4470
3.3540	4377.4484	5812.3504	4614.9753	252.1688	1421.9825	-3152.9469	1600.5189	1451.0268
3.2000	4903.4124	6510.9939	5170.0109	282.5579	1592.9415	-3532.0105	1792.9400	1657.4615
2.9000	6025.9454	8002.1084	6354.6722	347.4296	1957.8249	-4341.0581	2203.6302	2112.6129
2.6000	7279.6578	9667.5327	7677.8869	419.9015	2365.3707	-5244.6997	2662.3381	2641.4565
2.3000	8666.5451	11509.9252	9141.7755	500.0915	2816.2304	-6244.3798	3169.7968	3248.5880
2.0000	10188.2840	13531.5181	10748.1175	588.0979	3310.9509	-7341.3110	3726.6219	3938.3575
1.7000	11846.3153	15734.2286	12498.4400	684.0054	3850.0020	-8536.5347	4333.3420	4714.8519
1.4000	13641.8932	18119.7249	14394.0708	787.8871	4433.7920	-9830.9565	4990.4167	5581.7962
1.1000	15576.0896	20689.4317	16436.1429	899.8051	5062.6696	-11225.3497	5698.2387	6542.3614

0.8000	17649.78 51	23444.51 84	18625.58 46	1019.810 2	5736.921 1	12720.34 85	6457.129 8	7598.839 5
0.5000	19863.69 54	26385.93 38	20963.14 79	1147.943 3	6456.778 3	14316.46 75	7267.351 3	8751.475 4
0.2000	22218.63 28	29514.75 59	23449.68 79	1284.250 9	7222.505 0	16014.29 12	8129.199 9	9997.815 2
0.0000	23867.44 30	31705.42 15	25190.67 84	1379.693 3	7758.636 3	17203.03 95	8732.631 7	10879.22 48

Va +5 f -5	Vd 3.5st	Vd 1.5 f -5	Va -20 st	Va -25 f -5	Vd -6.5 st	Vd -8 f -5	flap
[Nm]	[Nm]	[Nm]	[Nm]	[Nm]	[Nm]	[Nm]	[Nm]
0.0000	0.0000	0.0000	0.0000	0.0000	0.0000	0.0000	0.0000
-0.0473	2.3244	0.8189	12.4005	10.7942	12.8485	11.3430	7.7006
4.2164	17.1361	9.0914	67.0081	58.4250	69.7576	61.7130	43.2709
9.8316	32.3085	18.3751	115.6655	100.7994	120.6131	106.6797	75.8247
19.1086	55.2473	32.8816	183.7231	159.8603	191.8782	169.5125	122.3052
49.6343	123.8701	77.9233	368.2436	319.2211	385.5643	339.6175	251.8491
100.1481	228.7149	149.0367	624.1180	539.1063	654.8216	575.1434	436.7192
175.2914	375.6054	251.2544	953.7941	821.1191	1002.524		
					9	878.1739	681.2202
279.7742	570.2440	389.5996	1358.672		1430.461	1249.817	
			9	1165.9363	6	2	989.0562
418.4294	818.3215	569.1643	1839.416		1939.653	1690.495	1363.534
			3	1573.5808	0	9	2
596.1982	1125.529		2396.093		2530.507	2200.083	1807.647
	8	795.1054	6	2043.5509	7	3	3
818.0857	1497.520		3028.250		3202.889	2777.971	2324.085
	5	1072.6028	4	2574.8891	2	6	8
943.3733	1703.486		3362.976		3559.460	3083.656	2602.239
	9	1227.6833	8	2855.3233	0	4	9
1088.7575	1939.474		3735.008		3956.196	3423.172	2915.076
	0	1406.4502	9	3166.3050	2	5	9
1413.6982	2457.287		4514.682		4789.030	4133.965	3582.729
	1	1802.2219	8	3815.7681	7	5	8
1797.2847	3055.532		5365.424		5699.750	4908.541	4328.359
	9	2264.3241	7	4521.2529	4	6	2
2243.9609	3738.805		6285.033		6686.351	5744.754	5153.119
	1	2797.2078	8	5280.4067	6	3	7
2757.9953	4511.432		7271.278		7746.774	6640.467	6057.957
	5	3405.1257	8	6090.9166	5	6	5
3343.5019	5377.464		8322.120		8879.121	7593.809	7043.636
	4	4092.1523	3	6950.7703	3	0	8
4004.3382	6340.577		9435.868		10081.81	8603.323	8110.767
	7	4862.0887	6	7858.4106	27	6	6
4743.8954	7403.892		10611.34		11353.74	9668.112	9259.817
	0	5718.2610	27	8812.8767	40	7	5
5564.9207	8569.640		11848.52		12694.90	10788.59	10491.03
	9	6663.3292	66	9814.6077	80	61	37
6469.0026	9837.979		13151.30		14108.99	11969.72	11804.13
	4	7698.7080	99	10868.837	80	63	28
7456.1249	11206.34		14528.98		15604.85	13222.62	13198.34
	91	8824.1234	21	11987.291	50	90	21
8159.8893	12172.60		15493.82		16652.10	14103.37	14172.60
	19	9623.8763	91	12774.493	23	63	67

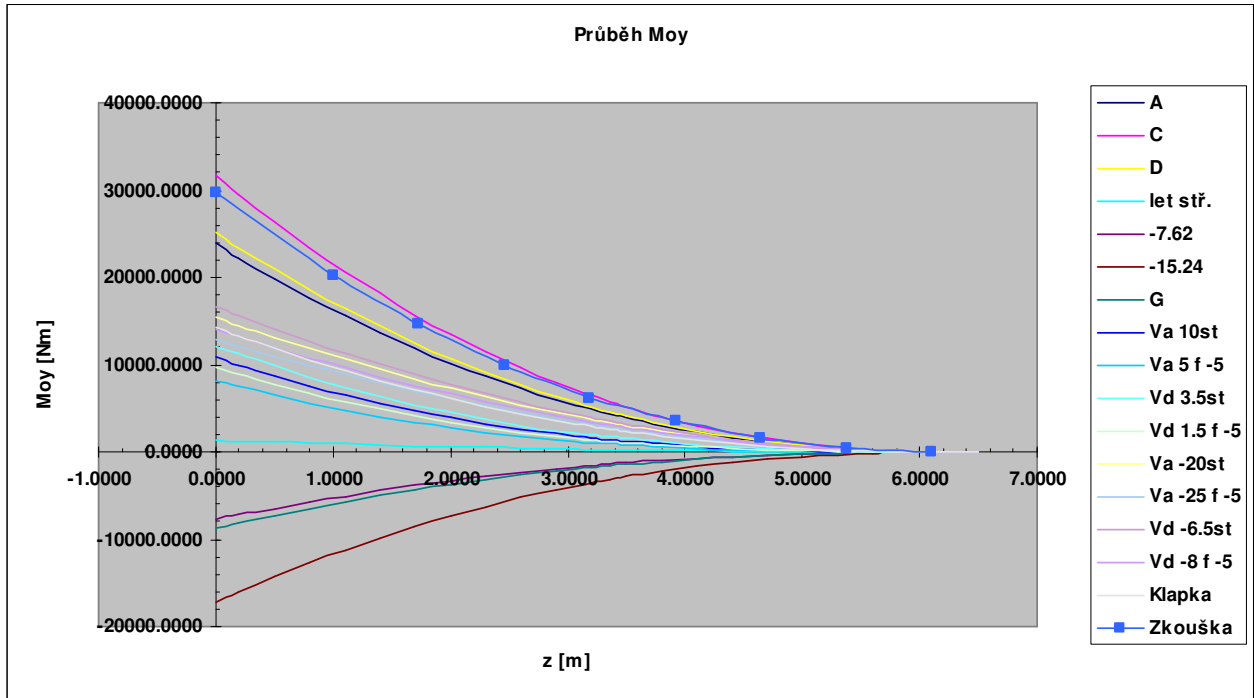

3.2.4 Comparison of Mox course

z	A	C	D	let stř.	-7.62	-15.24	G	Va 10st
[m]	[Nm]	[Nm]	[Nm]	[Nm]	[Nm]	[Nm]	[Nm]	[Nm]
6.5000	0.0000	0.0000	0.0000	0.0000	0.0000	0.0000	0.0000	0.0000
6.2000	0.5815	0.6483	-0.4367	-1.0566	0.0396	1.5083	0.7186	-0.7567
5.9000	6.6842	7.0395	-0.9466	-4.4743	0.9644	9.4792	4.5678	-2.3612
5.7540	13.4101	14.0225	-0.9094	-7.1123	2.0586	17.1078	8.2670	-3.1649
5.6000	23.5435	24.5197	-0.6210	-10.6492	3.7362	28.1529	13.6297	-3.9358
5.3000	53.2158	55.1966	0.8191	-19.8838	8.7229	59.3453	28.7924	-4.9072
5.0000	97.1697	100.5736	3.5923	-32.3577	16.1898	104.3159	50.6728	-4.7589
4.7000	156.6737	161.9507	7.8740	-48.2513	26.3643	164.1789	79.8162	-2.9567
4.4000	232.7748	240.4023	13.7947	-67.7405	39.4324	239.8810	116.6852	1.0271
4.1000	326.3745	336.8545	21.4554	-90.9977	55.5527	332.2594	161.6886	7.7249
3.8000	438.2592	452.1163	30.9339	118.1932	74.8622	442.0642	215.1923	17.6741
3.5000	569.1046	586.8839	42.2856	149.4946	97.4775	569.9622	277.5212	31.4114
3.3540	639.7987	659.6892	48.4976	166.2579	109.7061	638.9117	311.1252	39.6097
3.2000	719.4438	741.7078	55.5443	185.0530	123.4891	716.4984	348.9404	49.4335
2.9000	889.8544	917.1817	70.7725	224.9834	152.9983	882.2139	429.7139	72.3624
2.6000	1080.7716	1113.7503	88.0409	269.3275	186.0846	1067.4701	520.0191	100.7278
2.3000	1292.5734	1331.8004	107.4097	318.1244	222.8166	1272.5837	620.0113	135.0655
2.0000	1525.5665	1571.6457	128.9245	371.4114	263.2497	1497.8179	729.8192	175.8814
1.7000	1780.0047	1833.5464	152.6203	429.2249	307.4295	1743.3955	849.5520	223.6491
1.4000	2056.1000	2117.7201	178.5238	491.6002	355.3937	2009.5082	979.3034	278.7977
1.1000	2354.0236	2424.3427	206.6530	558.5719	407.1721	2296.3167	1119.1517	341.6883
0.8000	2673.9038	2753.5466	237.0178	630.1736	462.7869	2603.9494	1269.1596	412.5742
0.5000	3015.8322	3105.4265	269.6201	706.4380	522.2530	2932.5070	1429.3757	491.4574
0.2000	3379.9217	3480.0993	304.4664	787.3985	585.5897	3282.1062	1599.8571	578.0089
0.0000	3635.0407	3742.6270	328.9528	843.9970	629.9787	3526.9378	1719.2511	639.7679

Va +5 f -5	Vd 3.5st	Vd 1.5 f -5	Va -20 st	Va -25 f -5	Vd -6.5 st	Vd -8 f -5	flap
[Nm]	[Nm]	[Nm]	[Nm]	[Nm]	[Nm]	[Nm]	[Nm]
0.0000	0.0000	0.0000	0.0000	0.0000	0.0000	0.0000	0.0000
-0.9538	-0.6344	-0.6368	0.5738	0.3766	-0.6177	-0.6201	0.2527
-3.4145	-2.6194	-2.6321	4.2912	3.2379	-2.5360	-2.5487	3.6239
-4.9892	-4.1191	-4.1412	7.9984	6.1741	-3.9792	-4.0013	7.4471
-6.8642	-6.1111	-6.1465	13.3368	10.4084	-5.8946	-5.9300	13.2517
-10.9231	-11.2558	-11.3286	28.1757	22.1598	-10.8411	-10.9139	30.3676
-15.1913	-18.1350	-18.2613	49.1088	38.6764	-17.4597	-17.5860	55.8539
-19.2382	-26.8330	-27.0301	76.2974	60.0159	-25.8395	-26.0366	90.4694
-22.6250	-37.4345	-37.7208	109.7743	86.1223	-36.0713	-36.3576	134.8365
-24.8977	-50.0240	-50.4189	149.4818	116.8592	-48.2470	-48.6419	189.4869
-25.5890	-64.6862	-65.2099	195.2890	152.0260	-62.4597	-62.9834	254.8814
-24.2238	-81.5058	-82.1792	247.0013	191.3661	-78.8032	-79.4766	331.4116
-22.6881	-90.4945	-91.2486	274.2387	211.9409	-87.5533	-88.3073	372.7749
-20.3562	-	-	-	-	-	-	-
	100.559						
	7						
	-101.4044						
	304.3841						
	234.5944						
	-97.3638						
	-98.2085						
	419.3838						
-13.4064	-	-	-	-	-	-	-
	121.901						
	4						
	-122.9395						
	367.1375						
	281.3687						
	118.2062						
	-119.2443						
	519.1302						
-2.8666	-	-	-	-	-	-	-
	145.543						
	4						
	-146.7973						
	435.0053						
	331.4110						
	141.3530						
	-142.6069						
	630.9032						
11.7805	-	-	-	-	-	-	-
	171.497						
	3						
	-172.9895						
	507.6894						
	384.4044						
	166.8262						
	-168.3184						
	754.9210						
31.0308	-	-	-	-	-	-	-
	199.775						
	0						
	-201.5282						
	584.8879						
	440.0373						
	194.6478						
	-196.4010						
	891.3544						
55.3610	-	-	-	-	-	-	-
	230.389						
	0						
	-232.4259						
	666.3227						
	498.0346						
	224.8398						
	-226.8767						
	1040.332						
	9						
85.2166	-	-	-	-	-	-	-
	263.352						
	3						
	-265.6954						
	751.7583						
	558.1772						
	257.4235						
	-259.7665						
	1201.951						
	0						
120.9857	-	-	-	-	-	-	-
	298.678						
	9						
	-301.3502						
	841.0219						
	620.3194						
	292.4194						
	-295.0907						
	1376.270						
	7						
162.9775	-	-	-	-	-	-	-
	336.383						
	9						
	-339.4049						
	934.0835						
	684.4868						
	329.8464						
	-332.8674						
	1563.304						
	0						
211.3589	-	-	-	-	-	-	-
	376.486						
	0						
	-379.8762						
	1031.392						
	4						
	751.2939						
	369.7176						
	-373.1078						
	1762.942						
	3						
266.1000	-	-	-	-	-	-	-
	419.008						
	2						
	-422.7834						
	1134.060						
	6						
	822.1517						
	412.0377						
	-415.8129						
	1974.965						
	6						
306.0589	-	-	-	-	-	-	-
	448.711						
	9						
	-452.7510						
	1206.058						
	8						
	872.3498						
	441.6130						
	-445.6521						
	2123.113						
	3						

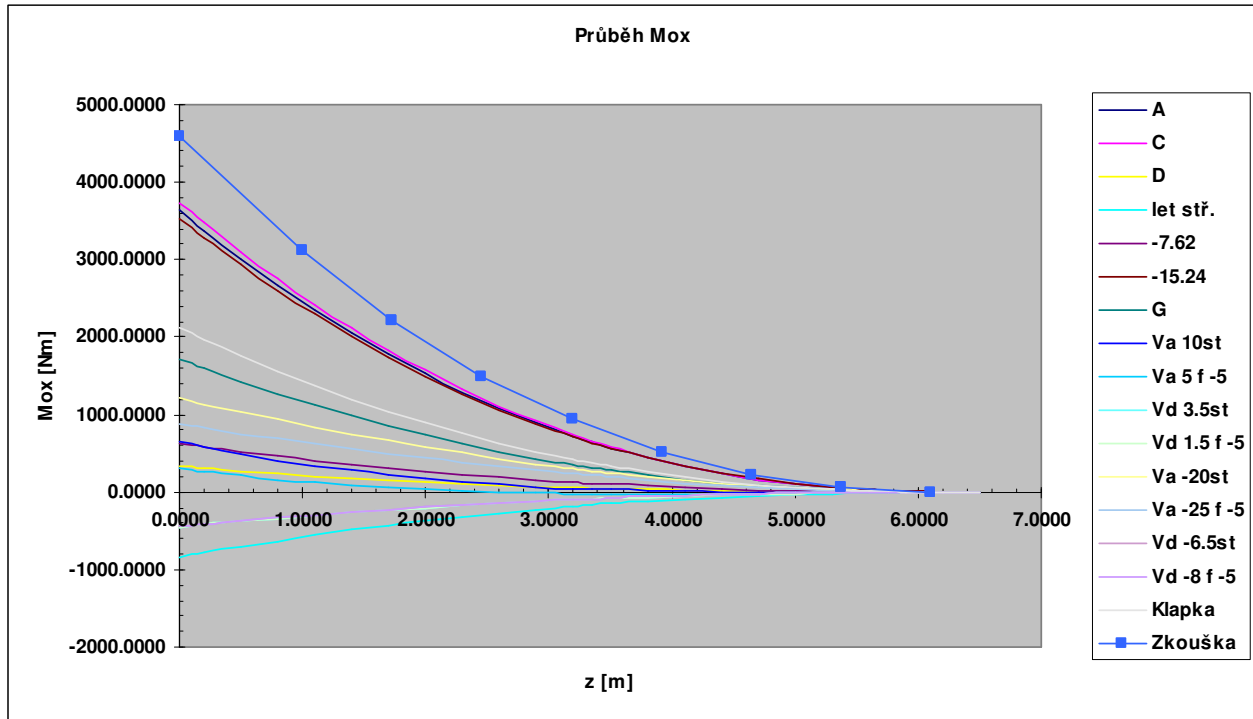

3.2.5 Comparison of Mky course

z	A	C	D	let stř.	-7.62	-15.24	G	Va 10st
[m]	[Nm]	[Nm]	[Nm]	[Nm]	[Nm]	[Nm]	[Nm]	[Nm]
6.5000	0.0000	0.0000	0.0000	0.0000	0.0000	0.0000	0.0000	0.0000
6.2000	12.5015	13.6255	-2.9772	-26.7005	-35.7687	-35.0773	-18.2339	-4.5491
5.9000	26.8814	28.8941	-8.6874	-61.3433	-81.4752	-79.1879	-41.1789	-9.7671
5.7540	33.7882	35.9792	-12.7909	-80.2942	106.1035	-102.5750	-53.3527	-23.4111
5.6000	41.5963	44.0222	-17.2676	101.4557	133.6462	-128.7701	-66.9871	-38.3862
5.3000	57.9228	60.6709	-27.5977	147.3805	193.1869	-185.1528	-96.3397	-70.1232
5.0000	74.7431	77.4432	-40.3507	198.2993	258.7065	-246.6814	128.3828	104.7538
4.7000	91.6587	93.7804	-56.1018	254.4918	330.3709	-313.3106	163.0974	142.5261
4.4000	108.3634	109.2473	-75.3270	316.2317	408.3764	-385.0623	200.4989	183.6703
4.1000	124.5905	123.4610	-98.4605	383.7907	492.9319	-461.9872	240.6167	228.4175
3.8000	140.0806	136.0488	125.9285	457.4399	584.2490	-544.1411	283.4833	277.0114
3.5000	154.5461	146.5999	158.1875	537.4521	682.5299	-631.5593	329.1207	329.7271
3.3540	161.2752	151.1567	175.1221	577.9502	732.0423	-675.3458	351.9859	356.4259
3.2000	168.5052	156.1029	193.0460	621.0049	784.7113	-721.9571	376.3253	384.4588
2.9000	182.8800	165.9847	228.4362	706.1978	888.9580	-814.2451	424.5155	438.7255
2.6000	197.3990	175.9180	264.4528	792.7136	994.7945	-907.9078	473.4243	492.7378
2.3000	211.9592	185.7625	301.2217	880.5853	1102.2185	1002.8961	523.0272	546.5914
2.0000	226.4758	195.4055	338.8298	969.8117	1211.1944	1099.1422	573.2897	600.3700
1.7000	240.8942	204.7714	377.3514	1060.4233	1321.7363	1196.6326	624.2053	654.1970
1.4000	255.1457	213.7691	416.8560	1152.4175	1433.8136	1295.3109	675.7454	708.2578
1.1000	269.1649	222.3086	457.4295	1245.8259	1547.4371	1395.1559	727.8997	762.8279
0.8000	282.8829	230.2982	-499.141	-1340.64	-1662.57	-1496.110	-780.639	-818.367
0.5000	296.2686	237.6938	-542.041	-1436.90	-1779.25	-1598.179	-833.966	-876.414
0.2000	309.5628	244.8178	-585.868	-1534.58	-1897.53	-1701.531	-887.966	-937.023
0.0000	318.3483	249.3961	-615.543	-1600.35	-1977.10	-1770.98	-924.257	-978.254

Va +5 f -5	Vd 3.5st	Vd 1.5 f -5	Va -20 st	Va -25 f -5	Vd -6.5 st	Vd -8 f -5	flap
[Nm]	[Nm]	[Nm]	[Nm]	[Nm]	[Nm]	[Nm]	[Nm]
0.0000	0.0000	0.0000	0.0000	0.0000	0.0000	0.0000	0.0000
-11.2283	-19.9260	-27.3022	9.7183	37.4323	-6.0763	9.2920	5.6559
-25.1933	-45.1510	-62.1698	18.7694	82.2389	-17.4501	17.7057	12.0123
-32.8360	-67.0570	-81.2787	43.7242	105.7214	-12.4764	21.2994	14.9263
-41.1302	-91.2585	-102.3771	71.4232	131.7530	-7.0816	25.1315	18.2501
-58.3382	-143.0592	-147.4109	130.0459	186.7989	3.1787	32.0394	25.1293
-76.7716	-199.9988	-196.7546	192.9965	245.8993	12.5591	37.8112	32.0258
-96.5418	-262.4672	-250.7076	260.1299	308.9470	20.6298	42.0525	38.6845
-117.7534	-330.8302	-309.5552	331.3864	375.9089	27.0502	44.4477	44.9062
-140.5175	-405.4517	-373.5862	406.7487	446.7888	31.5242	44.7206	50.5161
-164.9579	-486.7069	-443.1010	486.2227	521.6139	33.7783	42.6174	55.3435
-191.2254	-575.0041	-518.4289	569.8163	600.4171	33.5392	37.8885	59.2004
-204.4903	-619.7357	-556.5468	611.4625	639.6991	32.7680	34.9014	60.8066
-218.2357	-666.9476	-596.7232	655.5023	681.2290	31.7193	31.5002	62.5544
-244.2160	-759.197	-675.0376	741.5772	762.3510	28.6071	23.7459	66.0461
-269.4800	-851.818	-753.4851	827.8429	843.6112	24.3327	14.7799	69.5406
-294.0913	-944.924	-832.1536	914.3115	925.0429	18.8717	4.5981	72.9690
-318.0970	-1038.60	-911.0948	1001.038	1006.7410	12.2761	-6.7110	76.2664
-341.5666	-1132.99	-990.4021	1088.181	1088.9062	4.6633	-18.9891	79.3793
-364.6755	-1228.27	-1070.247	1175.858	1171.6690	-3.8506	-32.1086	82.2648
-387.6414	-1324.73	-1150.869	1264.372	1255.3807	-13.0070	-45.7665	84.8619
-410.7248	-1422.86	-1232.546	1354.560	1341.0784	-22.0105	-58.9783	87.0334
-434.7357	-1524.20	-1316.17	1449.614	1432.6741	-27.8574	-68.0665	88.4041
-459.9298	-1628.78	-1401.95	1549.447	1529.8801	-30.5919	-73.2630	89.2050
-477.2573	-1699.61	-1460.071	1617.006	1595.7339	-32.1038	-76.3732	89.6251

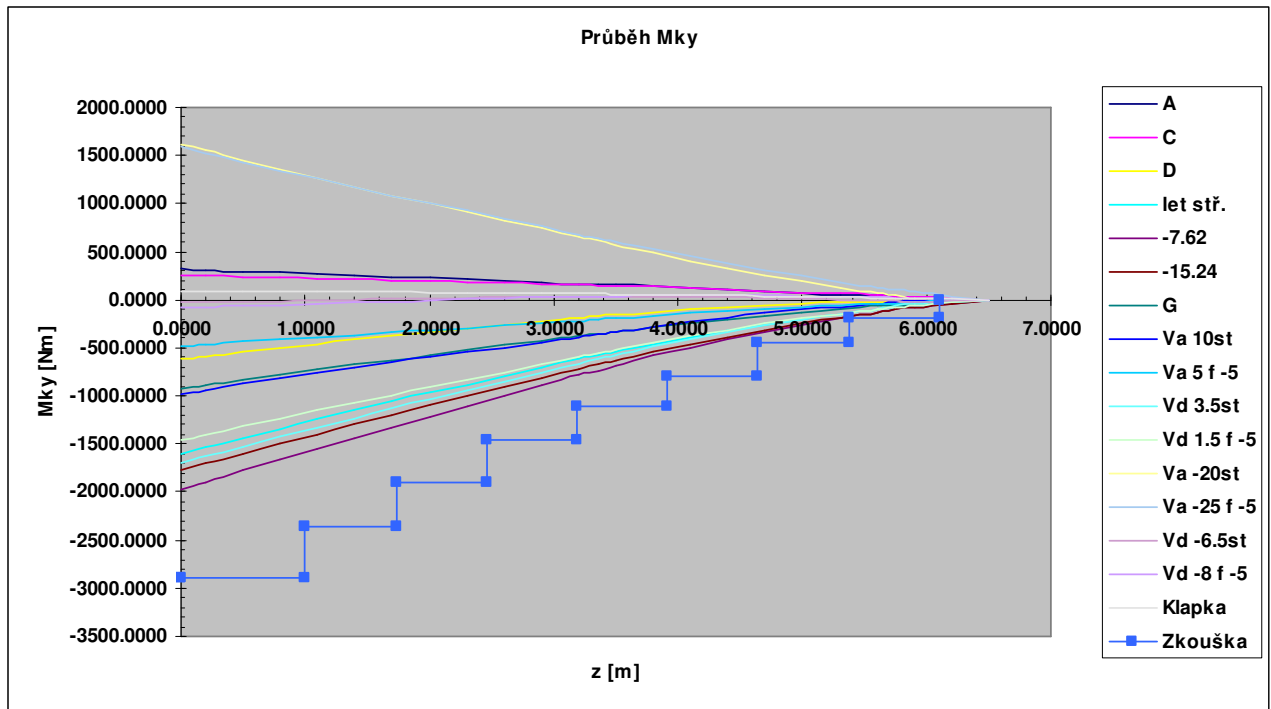

3.3 Comparison of tail surfaces

3.3.1 Horizontal tail unit (HTU)

3.3.1.1 Manouever on HTU

450 kg

JAR-VLA 423 (c)	v	δ	$\Delta\delta$	P _{vyv}	$\Delta\alpha$	Δclvop	ΔP_{man}	P _{man}
	[km/h]	[°]	[°]	[N]	[°]	[-]	[N]	[N]
Va	143.2852	-20.00	-20.00	-405.562	-9.47015	-0.55371	-653.037	-1058.6
Va	143.2852	14.00	14.00	-405.562	7.481418	0.437428	515.899	110.3371
Vd	252	-6.67	-6.67	-1305.44	-4.05864	-0.2373	-865.684	-2171.12
Vd	252	4.67	4.67	-1305.44	2.935746	0.171649	626.1781	-679.26

520 kg

JAR-VLA 423 (c)	v	δ	$\Delta\delta$	P _{vyv}	$\Delta\alpha$	Δclvop	ΔP_{man}	P _{man}
	[km/h]	[°]	[°]	[N]	[°]	[-]	[N]	[N]
Va	139.9344	-20.00	-20.00	-501.05	-9.47015	-0.55371	-622.851	-1123.9
Va	139.9344	14.00	14.00	-501.05	7.481418	0.437428	492.0524	-8.99756
Vd	221.1663	-6.67	-6.67	-1195.79	-4.05864	-0.2373	-666.801	-1862.59
Vd	221.1663	4.67	4.67	-1195.79	2.935746	0.171649	482.3194	-713.473

3.3.1.2 Gust on HTU

450 kg

JAR-VLA 425 (d)	v	U _{de}	P _{vyv}	ΔP_{por}	P _{por}
	[km/h]	[m/s]	[N]	[N]	[N]
Vc	175	15	-616.941	786.2069	169.2657
Vc	175	-15	-616.941	-786.207	-1403.15
Vd	252	7.5	-1305.44	566.0689	-739.369
Vd	252	-7.5	-1305.44	-566.069	-1871.51

520 kg

JAR-VLA 425 (d)	v	U _{de}	P _{vyv}	ΔP_{por}	P _{por}
	[km/h]	[m/s]	[N]	[N]	[N]
Vc	176.9331	15.24	-776.466	833.0524	56.58599
Vc	176.9331	-15.24	-776.466	-833.052	-1609.52
Vd	221.1663	7.62	-1195.79	520.6578	-675.135
Vd	221.1663	-7.62	-1195.79	-520.658	-1716.45

3.3.2 Vertical tail unit (VTU)

3.3.2.1 Manoeuvre on VTU

450 kg

JAR-VLA 441 (a)(1)	v	δ	$\Delta\delta$	$\Delta\alpha$	Δcl_{vop}	ΔP_{man}	P _{man}
	[km/h]	[°]	[°]	[°]	[-]	[N]	[N]
Va	143.2852	-30.00	-30.00	-12.5226	-0.43712	-436.225	-436.225
Va	143.2852	30.00	30.00	12.52262	0.437122	436.2249	436.2249
Vd	252	-10.00	-10.00	-6.45105	-0.22518	-695.095	-695.095
Vd	252	10.00	10.00	6.451046	0.225184	695.0947	695.0947

520 kg

JAR-VLA 441 (a)(1)	v	δ	$\Delta\delta$	$\Delta\alpha$	Δcl_{vop}	ΔP_{man}	P _{man}
	[km/h]	[°]	[°]	[°]	[-]	[N]	[N]
Va	139.9344	-30.00	-30.00	-12.5226	-0.43712	-416.061	-416.061
Va	139.9344	30.00	30.00	12.52262	0.437122	416.0611	416.0611
Vd	221.1663	-10.00	-10.00	-6.45105	-0.22518	-535.403	-535.403
Vd	221.1663	10.00	10.00	6.451046	0.225184	535.4031	535.4031

3.3.2.2 Gust on HTU

450 kg

JAR-VLA 443 (b)	v	U _{de}	ΔP_{por}	P _{por}
	[km/h]	[m/s]	[N]	[N]
Vc	175	15	528.764	528.764
Vc	175	-15	-528.764	-528.764
Vd	252	7.5	380.710	380.710
Vd	252	-7.5	-380.710	-380.710

520 kg

JAR-VLA 443 (b)	v	U _{de}	ΔP_{por}	P _{por}
	[km/h]	[m/s]	[N]	[N]
Vc	176.9331	15.24	571.713	571.713
Vc	176.9331	-15.24	-571.713	-571.713
Vd	221.1663	7.62	357.321	357.321
Vd	221.1663	-7.62	-357.321	-357.321

3.3.3 Add moment from T configuration of tail unit - HTU on VTU

3.3.3.1 Manoeuvre

450 kg

ACJ VLA 441	v	δvk	η	β	Mr
	[km/h]	[°]	[-]	[-]	[Nm]
Va	143.2852	-30	0.557	-0.219	-207.292
Va	143.2852	30	0.557	0.219	207.292
Vd	252	-10	0.771	-0.101	-295.871
Vd	252	10	0.771	0.101	295.871

520 kg

ACJ VLA 441	v	δvk	η	β	Mr
	[km/h]	[°]	[-]	[-]	[Nm]
Va	139.9344	-30	0.557	-0.219	-197.711
Va	139.9344	30	0.557	0.219	197.711
Vd	221.1663	-10	0.771	-0.101	-227.898
Vd	221.1663	10	0.771	0.101	227.898

3.3.3.2 Gust

450 kg

ACJ VLA 443	v	Ude	Mp
	[km/h]	[m/s]	[Nm]
Vc	175	15	522.5391
Vc	175	-15	-522.5391
Vd	252	7.5	376.2281
Vd	252	-7.5	-376.2281

520 kg

ACJ VLA 443	v	Ude	Mp
	[km/h]	[m/s]	[Nm]
Vc	176.9331	15.24	536.7640
Vc	176.9331	-15.24	-536.7640
Vd	221.1663	7.62	335.4775
Vd	221.1663	-7.62	-335.4775

4. Strength check of the critical points of the structure.

4.1 HTU and rudder VTU.

HTU and VTU, as it emerges from comparing of loads, comply with MTOW 520 kg. The load was increased in the critical cases; in the case of inductive moment on T of the tail unit from gust VTU at the speed v_c .

The critical points as the main hinges they have a high safety coefficient f . The re-count for the higher load is in following.

HTU is connect with two pins of $\varnothing 10$ mm. The scheme of the connection is on the picture:

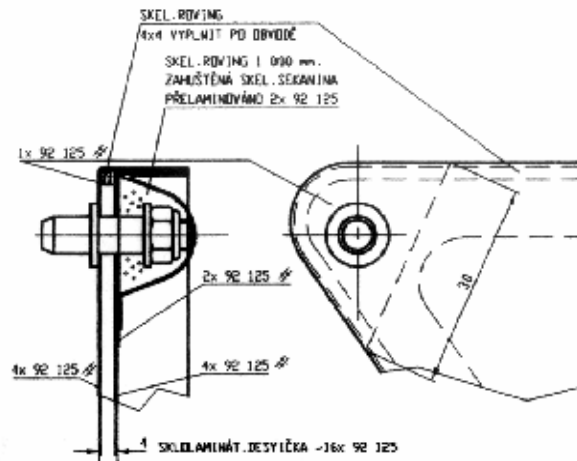

For load of connection ist most important inductive moment on the HTU from gust on VTU. Its value is $M_T=536$ Nm.

The load from the moment on pin is $R = \frac{Mt}{r}$ there $r=100$ mm is the pitch of the pins.

$$R = \frac{536764}{100} = 5367N$$

Max. load of connection is thus $R = 5367N$.

In the hinge of HTU there is the force transfered thru the pins $d= 10$ mm to the laminat $t=5.5$ mm.

$$\sigma_{\text{otlačení}} = \frac{R}{t \cdot d} = \frac{5367}{5.5 \cdot 10} = 97.58 \text{ MPa} < \sigma_{\text{Dov.}} = 140 \text{ MPa} , \text{comply}$$

In the proper structure of HTU there is the force transfered to the laminat thru the bushing $d=18$ mm , the laminat $t = 4.2$ mm

$$\sigma_{\text{otlačení}} = \frac{R}{t \cdot d} = \frac{5367}{4.2 \cdot 18} = 71 \text{ MPa} < \sigma_{\text{Dov.}} = 140 \text{ MPa} , \text{comply}$$

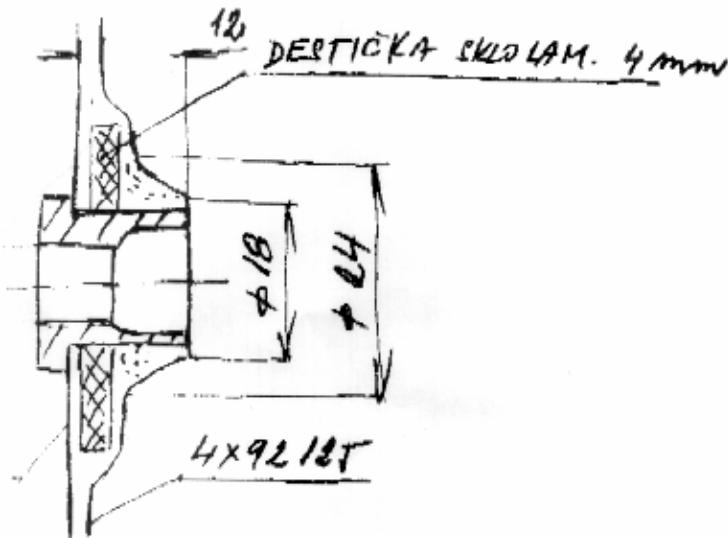

We compare this with loading of HTU and VTU of UFM-11. The applied parts are identical and if only because the UFM-11, has higher loads in the UL category then the UFM-13, was the strength proof done for it.

4.2 Control system.

In the control lines there is not appeared the MTOW 520 kg. At first the increasing of hinge moment there is not, second the decisive cases usually are the loads from pilots. In the proof of control system there was prevent used the load under JAR - VLA.

4.3 Engine mount and attachment.

The enhancement of MTOW 520 kg there is not the essential increase of the n (proof of UFM-11 $n_y=4.85$, UFM-13 Experimental $n_y=4.95$, increase about 2%) and this is why even load on the engine mount comply.

4.4 Landing gear mount.

Origin undercarriage has not proof for the MTOW 520 kg. This is why we postulate a new load for this weight according regulations JAR-VLA.

4.4.1 Description of the landing gear of the airplane

The landing gear with nose wheel and main wheels

4.4.1.1 Main landing gear

Shock-absorber: on the main landing gear the function of shock-absorber has the fibre glas main leg

Tires : 400x100

4.4.1.2 Nosewheel leg

*Shock-absorber: steel fork with rubber shock-absorber
Tire : 400x100.*

4.4.2 Configuration of the weight

The calculation of load of landing gear was provided for the MTOW 520 kg. The load is calculated for the front position of CG.

4.4.3 Falling speed at landing

For the value of load is decisive the design of the falling speed. This is defined under regulations or it recommends a method how calculate it.

JAR-VLA 473 Conditions and assumptions of loads underfoot.

The operating coefficient of the vertical force on inertia, specified in this section of regulation, has not to be lesser than multiple which would be arise at landing at falling speed $0,51(Mg/S)^{1/4}$. This falling speed has to be higher than 3,05 m/s and has not to be lesser than 2,13 m/s.

For definite configuration of the airplane works out

$$v_y = 0,51(Mg/S)^{1/4} = 2,308 \text{ m/s}$$

4.4.4 Loads of landing gear.

For the calculation of load of landing gear we use Appendix JAR-VLA, which we will conform in future.

4.4.4.1 UNDERFOOT LOAD

JAR-VLA 471 Generally

The operating load, specified in this section are outside load and forces of inertia, which act of the structure of the aircraft. In every of conditions of underfoot load have to be outside load in balance with shift and rotation forces, which are lay down by consideration or under experiences (rationally or conservately)

JAR-VLA 473 Conditions and assumptions of loads underfoot

a) The demands of underfoot loading in this section have to be fulfilled at the max. weight 520 kg. Chosen operating coefficient of the vertical force on inertia in CG of the airplane for underfoot load, specified in this section of regulation, has not to be lesser than multiple which would be arise at landing at falling speed $0,51(Mg/S)^{1/4}$. This falling speed has to be higher than 3,05 m/s and has not to be lesser than 2,13 m/s.

It can be assumed, that during landing acts the lift of wing which don't exceed 2/3 of MTOW in CG. Multiple of operating load can be equal with multiple of forces of inertia, which are diminished about assumed ratio of wing lift to MTOW.

If is provided the proof test of absorbed energie for the postulate of operating coefficient, which comply with operating falling speed, must be provided according JAR-VLA 725.

In any case has not to be the multiple of load from forces of inertia used for design purpose lesser then 2,67 and the multiple for reaction from ground at MTOW lesser then 2,0, if the lesser values will be not excced at taxi with speed for take-off on the realistic ground.

JAR-VLA 477 Configuration of landing gear

The points of JAR-VLA 479 - 483 or conditions, stated in Appendix C of this regulations are relate on airplanes with nose wheel landing gear and rear wheel landing gear.

The simplify demands are stated in tab on next page.

4.4.5 BASIC CONDITIONS FOR LANDING

Conditions	Rear gear		nose wheel		
	horizontal landing	Landing with big angle of attac	horizontal landing with declinated reactions	Horizontal landing with nose wheel near to ground	Landing with big angle of attac
Competent section	JAR-VLA 479(a)(1)	JAR-VLA 481(a)(1)	JAR-VLA 479(a)(2)(i)	JAR-VLA 479(a)(2)(ii)	JAR-VLA 481(a)(2) a (b)
Verticat component in CG	nW	nW	nW	nW	nW
Forward component of drag in CG	KnW	0	KnW	KnW	0
Side component in both directions in CG	0	0	0	0	0
Lifting of hydraulic shock-absorber	Notice 2	Notice 2	Notice 2	Notice 2	Notice 2
Lifting of shock absorber (spring or rubber)	100 %	100 %	100 %	100 %	100 %
Propérování pneumatiky	static	static	static	static	static
load Vr of main leg of landing gear	(n-L) W	(n-L) Wb/d	(n-L) Wb/d'	(n-L) W	(n-L) W
Dr (both wheel)	k n W	0	k n Wa/d	k n W	0
load Vf of rear gear (nose wheel)	0	(n-L)Wa/d	(n-L) Wb/d'	0	0
	0	0	k n Wb/ d'	0	0
Notices	(1)(3)(4)	(4)	(1)	(1)(3)(4)	(3)(4)

Notices 1) K we postulate : $K=0,25$ pro $W=1361$ kg or less
 $K=0,33$ pro $W=2722$ kg or more

With linear changing

2) For all of designs is assumption: max. coefficient is on shock absorber in lift for springing 25-100 %, if it is not proof other matter and n load must be use for every position of shock absorber, which are critical for landing gear parts.

3) Unbalanced moments must be balanced with acceptable method.

4) L is postulate according JAR-VLA 725 (b)

5) n is oparating coefficient of load in CG according JAR-VLA 473

(d) a (g).

4.4.6 Horizontal landing

JAR-VLA 479 conditions for horizontal landing

(a) For horizontal landing is assumed that the airplane will be in position in following:

- (1) Airplane with rear landing gear, standard position for horizontal fly
- (2) Airplane with nose wheel; the position, in which:
 - (i) nose wheel and the main wheels have touch at the same time
 - (ii) main wheel are touching, the nose wheel is nearly from ground.

The position in (a) (2)(i) of this section can be use in analyzis in section (a) (2) (ii).

Component of drag can no lesser then 25 % of max. vertical reactions from ground (we assume the influence from wing lift) must be adequate combiny with vertical reactions (see. ACJ VLA 479 (b)).

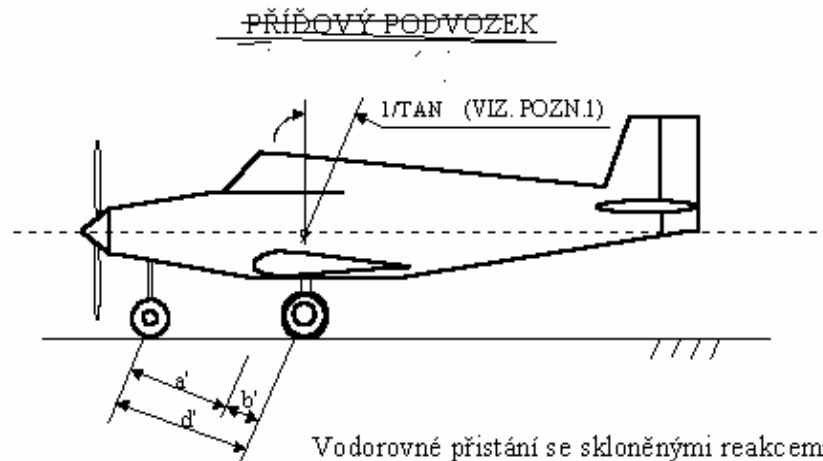

4.4.7 Landing with a big angle of attack

JAR-VLA 481 Conditions for landing with a big angle of attack

For landing with big angle of attack is assumed that the aircraft will be in positions in following:

- The aircraft with rear landing gear: position in which the main wheel and rear gear have touch in the same
- The aircraft with nose wheel, falling position or max angle which allows the gap between ground. It will be used the lesser value.

For the aircraft with nose wheel or rear wheel there is assumed that the reactions from ground are vertical and the wheels have acceleration of the adequate circumference speed before max. vertical load.

KLASICKÝ PODVOZEK

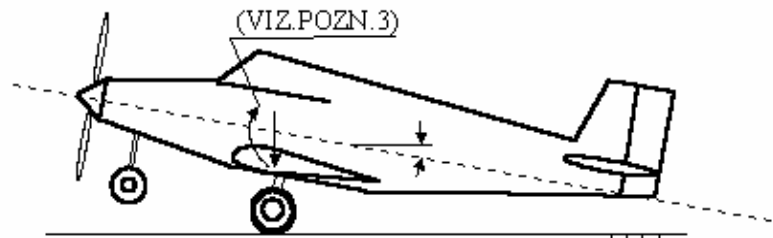

POZN. VIZ JAR-VLA 48 (a)(2)

Přistání s velkým úhlem náběhu

4.4.8 Multiple in CG at taxi.

To the postulate the multiple in CG of aircraft we are using a very simple method from Canadian UL regulations. For more detailed calculation are not the available data

1. From falling speed we calculate the height for down fall test of airplane from equality of potential energy

$$h = \frac{v^2}{2 \cdot g} = 0,271 \text{ m}$$

2. We postulate the supposed declension of CG of aircraft at max. compressing of tire and shock-absorber too. Because the absorbing make the tires ($ep = 0.5$) and main landing gear leg, the declension will be different for the nose wheel and rear wheel configuration.

- For our configuration we suppose whole declension $d=0.175$ m. Declension of legs is $dt=0.105$ and tire $dp=0.07$. On this value must be the tire pressure and the resilience of main leg set up for the correct calculation.

3. We make out the multiple with the formula:

$$n_y = \frac{h + \frac{d}{3}}{ep \cdot dp + et \cdot dt} = 3.77 \text{ g}$$

4. Multiple in CG with component of wing lift at landing:

$$n_{yt} = n_y + 0.67 = 4,44 \text{ g}$$

This is the basic operating value in CG at landing

4.4.9 Additional conditions for load of landing gear:

4.4.9.1 Sideward load

JAR-VLA 485 Condition for sideward load

For sideward load is assumed the aircraft is in horizontal position, only the main wheels are touching with ground, the tires and shock-absorber have static compression.

Operating multiple of vertical load must be 1,33 with vertical component of reactions from ground, the both component of reaction on main wheels are the same.

Operating multiple of sideward load must be 0,83 from sideward ground reactions which are distributed to the components:

- (1) 0,5(Mg) acts inside on one wheel
- (2) 0,33(Mg) acts outside on second wheel.

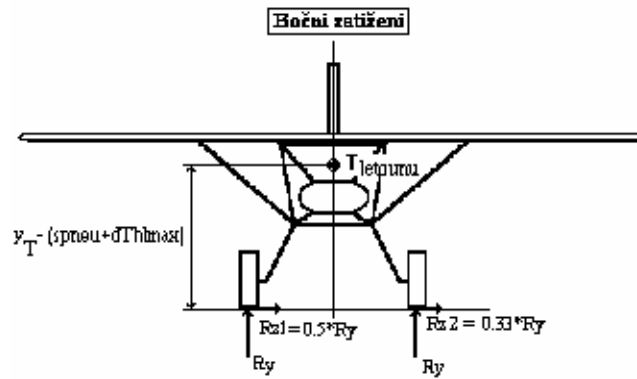

4.4.9.2 Braking at taxi

JAR-VLA 493 Conditions of braking at taxi

For conditions of braking at taxi, if the shock absorber and tires are pressed statically, there hold the demands as in following:

Operating multiple of vertical load must be 1,33

The position of the aircraft and touching with ground must correspond JAR-VLA 479 for horizontal landing.

The drag reaction is equal with vertical reaction on the wheel, multiplied with friction coefficient 0,8 and it must be leaded on the point of touch with ground for the every braked wheel.

The drag reaction may not exceed max. value at limit brake moment.

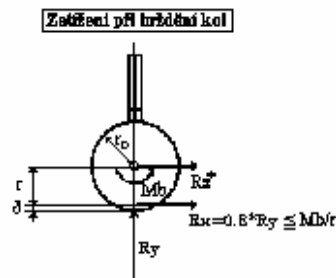

4.4.9.3 Additional conditions for the nose gear

JAR-VLA 499 Additional conditions for the nose gear

For additional conditions for the nose gear and it mount there is supposed, that the shock-absorbes and tires are pressed statically. Futher must be fullfilled the conditions in following:

(a) For load in backward direction must be the component of operating force on the pin as follow: :

- (1) vertical component 2,25 x statical load on the wheel and
- (2) drag component 0,8 x vertical load

(b) For load in forward direction must be the components of operating force on the pin as follow:

- (1) vertical komponent 2,25 x statical load on the wheel and
- (2) forward component 0,4 x vertical load

(c) For sidewards load must be the components of operating force at touching with ground as follow:

- (1) vertical component 2,25 x statical load on the wheel
- (2) sidewards component 0,7 x vertical load

Previous conditions of the regulations are for all of cases reproached in the tab in following as the wheel reaktions. We give the values for the backward position of CG, which is for MTOW more realistic.

Additional conditions can be adapted for actual structure of solution of the nose landing gear.

Loading case of nose wheel landing gear

mletounu =	520	[kg]							
Skřídla=	12.16	[m ²]					dpneu	0.07	[m]
Vklesací							dtlum	0.105	[m]
	JAR-VLA	2.308101	[m/s]				ef pneu	0.5	[]
	Vklesv	2.308101	[m/s]				ef tlum	0.5	[]
	H pádová	0.271526	[m]				mred	383	[kg]

Případ předpisu	Hlavní podvozek						Přídový		
	Levé kolo			Pravé kolo			Rx	Ry	Rz
	Rx	Ry	Rz	Rx	Ry	Rz			
[N]	[N]	[N]	[N]	[N]	[N]	[N]	[N]	[N]	
JAR-VLA 479 (a) (2) (i)	1963.706	6669.474	0	1963.706	6669.474	0	867.3431	2945.819	0
JAR-VLA 479 (a) (2) (ii)	2831.049	9615.293		2831.049	9615.293	0	0	0	0
JAR-VLA 481 (a) (2)	0	9615.293	0	0	9615.293	0	0	0	0
JAR-VLA 485	0	3392.298	1696.149	0	3392.298	1119.458	0	0	0
JAR-VLA 493	2713.838	3392.298	0	2713.838	3392.298	0	0	0	0
JAR-VLA 499 (a)	0	0	0	0	0	0	2142.145	2677.681	0
JAR-VLA 499 (b)	0	0	0	0	0	0	-1071.07	2677.681	0
JAR-VLA 499 (b)	0	0	0	0	0	0	0	2677.681	1874.377

nyt = 3.769816	φPřed.k.=	400 [mm]
nyt = 4.439816 []	φ Hlav.k.=	400 [mm]
Geometrie podvozku viz výkres	yt=	700 [mm]
a = 1308 [mm]	a' =	1147.836 [mm]
b = 398 [mm]	b' =	506.9841 [mm]
d = 1706 [mm]	d' =	1654.82 [mm]

4.4.10 Check of landing gear

Landing gear will check through the downfall test. For the basic cases is possible to think downfall test proper also for nose landing gear. The additional cases we prove arithmetically,

Nose landing gear is a welded steel part. His basic dimension are on the picture with two critical points k1 and k2.

The decisive case of load is the combination of force Rx=2142N and vertical force Ry=2677N

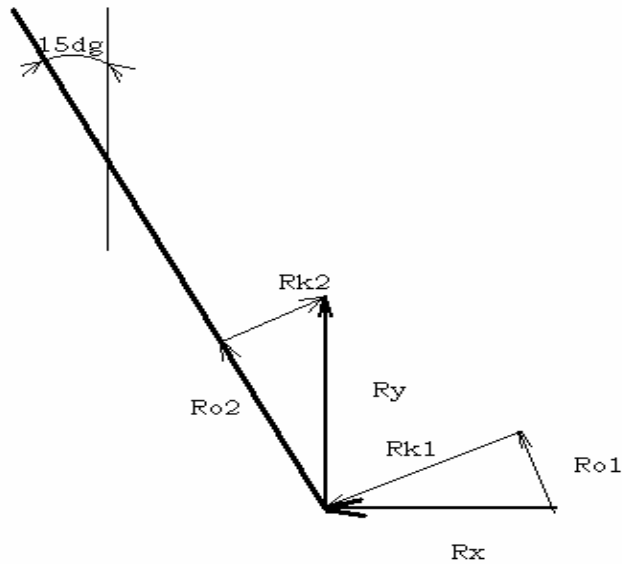

we provide the resolution on the plane of leg:

$$R_{o1} = R_x \sin 15 = 554.39 \text{ N}$$

$$R_{o2} = R_y \cos 15 = 2585.78 \text{ N}$$

$$R_{k1} = R_x \cos 15 = 2069 \text{ N}$$

$$R_{k2} = R_y \sin 15 = 692.85 \text{ N}$$

$$R_o = R_{o1} + R_{o2} = 3140,17 \text{ N}$$

$$R_k = R_{k1} - R_{k2} = 1376,15 \text{ N}$$

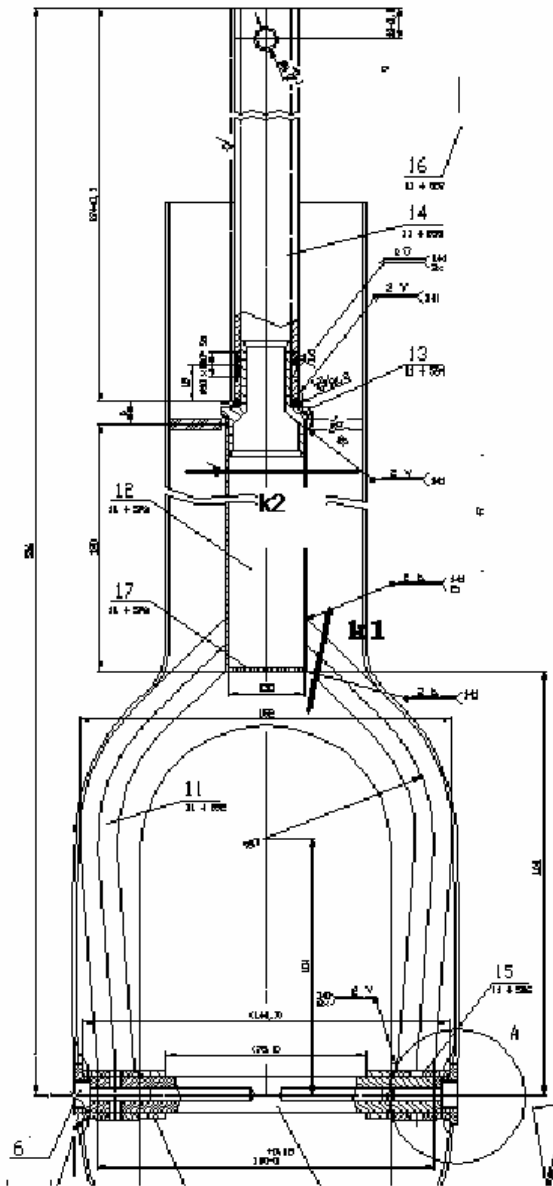

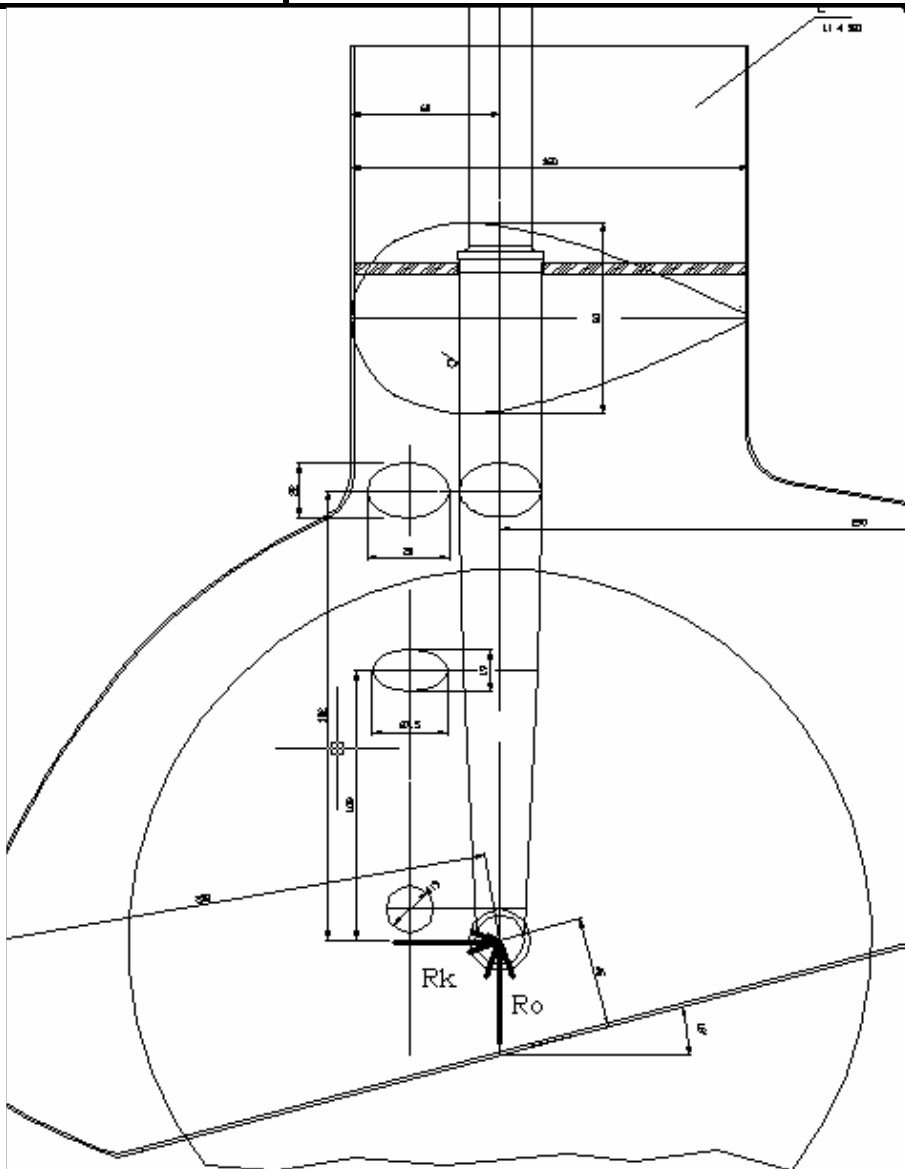

Cross-section k1 is loaded with combination of torsion, transfer force and bending

$$M1 = R_o / 2 \cdot 44 = 69080 \text{ Nmm}$$

$$M2 = R_k / 2 \cdot 44 = 30272 \text{ Nmm}$$

$$M_k = R_k / 2 \cdot 165 = 113532 \text{ Nmm}$$

Check of the cross-section is in tab. in following:

Check of cross-section k1, nose wheel

Description

520kg

load	dimension	stress
M1= 69080[Nmm]	W1= 402[mm ³]	Sigo1= 171.8408[MPa]
M2= 30272[Nmm]	W2= 460[mm ³]	Sigo2= 65.8087[MPa]
T1= 1570[N]	Wk= 871[mm ³]	Sig Fo= 0[MPa]
T2= 1338.5[N]	S= 75.4[mm ²]	Tau1= 27.76235[MPa]
Fo= 0[N]	k1 smyk= 1.3333[]	Tau2= 23.66873[MPa]
Mk= 113532[Nmm]	k2 smyk= 1.3333[]	Taukrut= 130.3467[MPa]
	Sig red = 381.0351[MPa]	K plastic = 1.27[]
	Sig krit = 800[MPa]	
	f= 2.099544[]	f= 2.666421

Cross-section k2 is loaded with transfer force.

$$M1 = Rk \cdot 0.365 = 502240 \text{ Nmm}$$

$$F_o = R_o = 3140,17 \text{ N}$$

Check of cross-section k2.

Check of cross-section k2

Description

load	dimension	stress
M1= 502140[Nmm]	W1= 1046[mm ³]	Sigo1= 480.0574[MPa]
M2= 0[Nmm]	W2= 1046[mm ³]	Sigo2= 0[MPa]
T1= 1570[N]	Wk= 2092[mm ³]	Sig Fo= 21.83588[MPa]
T2= 0[N]	S= 143.8[mm ²]	Tau1= 14.55689[MPa]
Fo= 3140[N]	k1 smyk= 1.3333[]	Tau2= 0[MPa]
Mk= 0[Nmm]	k2 smyk= 1.3333[]	Taukrut= 0[MPa]
	Sig red = 502.737[MPa]	K plastic = 1.27[]
	Sig krit = 600[MPa]	
	f= 1.193467[]	f= 1.515703

The safety in cross-section k2 is under practical operating unsatisfactory, this is why was the tube 28/1.5 inserted.

4.5 Fuselage of aircraft.

Because don't come about the enhancement of essential load forces, engine, crew, the forces on HTU and VTU it is supposed that the fuselage comply with regulations and it is equally proved with tests, which are described in Technical report UFM-11. From stand point of evidence they are identical fuselage.

4.6 Wing of aircraft.

Here shows the enhancement of MTOW mostly and it is necessary the check of the most critical points.

The wing of UFM-11 is as regards the strength scheme of structure identical with the wing of UFM-13. In the both cases it is a wing with one spar, two cavities with sandwich covering. The spar is created from carbon fibre flange plates, which are stucked on sandwich spar web of the I-form.

For the strength check there are prove:

- flange plate of the spar
- spar web
- covering of the cavities
- root rib and its gripping
- suspension of flaperon
- flaperon

4.6.1 Check of flange plate of the spar

The flange plate is from carbon fibre roving. The tips of wing have flange plate from glassfibre with one-way fabric 92145.

Scheme is on the picture

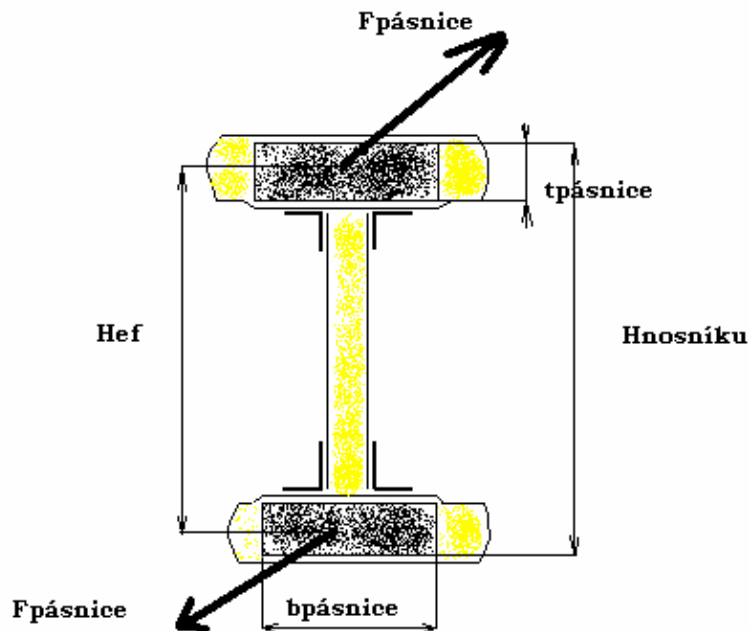

The flange plates transfer the forces in axis of flange from bending moment. The forces we count up under formula:

$$F_{pásnice} = \frac{M_o}{H_{ef}} \text{ [N]}$$

M_o bending moment of the wing [Nmm]

H_{ef} distance of flange CG [mm] $H_{ef} = H_{nosníku} - t_{pásnice}$

$$\text{Stress in the flange } \sigma_{pásnice} = \frac{F_{pásnice}}{b_{pásnice} \cdot t_{pásnice}}$$

The values of stress at arithmetical load $f=1,5$ from max. bending moment are in tab. in following.

Black values are for carbon

Blue values are for glass

Braun values are for hybrid flange in the place where is touch between carbon and glass and place of carbon flange with add the one-way fabric 92145 in supporting structure of band. Thickness of this fabric we add to flange as 0.69 mm to glass flange and 0.169 mm to carbon flange. In this case we provided the reduction in the ratio of E-moduls glass/carbon. pásnici. V tomto případě jsme provedli redukci v poměru Emodulů skla a uhlíku

$$\frac{t_{red}}{t_{sklo}} = \frac{E_{sklo}}{E_{uhlík}}$$

UFM-13 $f=1.5$

Pásnice $b=$

60.5[mm]

With influence
3x92145

JAR-VLA

z	HH	Moy	Moy	th	td	σ_h	σ_d	σ_h	σ_d
[m]	[mm]	[Nm]	[Nm]	[mm]	[mm]	[MPa]	[MPa]	[MPa]	[MPa]
5.7500	111.827	254.008	-105.694	0.230	0.230	192.97	192.97	61.61	61.61
5.6000	115.000	409.849	-171.210	0.361	0.361	191.97	191.97	81.45	81.45
5.3000	121.592	844.134	-354.285	0.624	0.624	214.97	214.97	120.39	120.39
5.0000	128.103	1463.761	-616.062	0.887	0.887	247.44	247.44	159.35	159.35
4.7000	134.260	2283.087	-962.691	1.150	1.150	282.62	282.62	198.13	198.13
4.4000	140.988	3314.487	-1399.462	1.380	1.323	323.71	337.79	238.84	246.41
4.1000	147.530	4569.034	-1931.093	1.610	1.495	363.69	391.67	278.77	294.92
3.8000	154.071	6056.772	-2561.852	1.840	1.668	402.08	443.68	317.47	342.84
3.5000	160.613	7786.755	-3295.577	1.660	1.840	546.54	493.08	509.66	389.31
3.3500	163.884	8718.526	-3690.840	1.800	1.260	550.79	786.85	516.34	718.36
3.2000	164.497	9766.491	-4135.440	2.000	1.600	553.99	692.49	522.61	644.13
2.9000	165.722	12003.163	-5084.500	2.700	1.900	501.85	713.15	480.47	670.75
2.6000	166.947	14501.299	-6144.709	3.500	2.100	465.41	775.68	449.96	733.71
2.3000	168.172	17264.888	-7317.786	4.000	2.600	482.46	742.25	468.40	709.47
2.0000	169.397	20297.277	-8605.170	4.800	3.100	470.84	729.04	459.34	701.84
1.7000	170.622	23601.343	-10008.093	5.300	3.300	492.92	791.67	482.00	763.86
1.4000	171.848	27179.587	-11527.624	6.200	3.900	483.72	768.99	474.52	746.01
1.1000	173.073	31034.148	-13164.673	6.900	4.800	494.88	711.39	486.41	694.02
0.8000	174.298	35166.778	-14919.982	8.100	5.900	477.46	655.50	470.49	642.42
0.5400	175.360	39578.901	16794.1506	10.200	8.500	430.42	516.51	425.41	509.31

From the strength aspect of the flange comply with conservative assumptions. We are using the strength characteristic of the materials:

$$\sigma_{\text{Ptsklo}}=900 \text{ MPa}$$

$$\sigma_{\text{Pdsklo}}=490 \text{ MPa}$$

$$\sigma_{\text{Ptuhlik}}=1150 \text{ MPa}$$

$$\sigma_{\text{Pduhliko}}=800 \text{ MPa}$$

We figure the min. value of safety coefficient for the tension and press in the carbon-fibre and glass-fibre flange

$$f_{\text{min tlak sklo}}=2,318$$

$$f_{\text{min tah sklo}}=3,47$$

$$f_{\text{min tlak uhlik}}=2,298$$

$$f_{\text{min tah uhlik}}=2,26$$

$f_{\text{min celková}}=2,26 > 2.25$ as is coefficient of safety demanded from JAR, with inclusion of extreme surrounding influences.

ACJ VLA 572 (b) postulated the values of max. stress of carbon and glass. If will be not this values exceeded it is not necessary to check the fatigue of spar of airplane.

For carbon $\sigma_{f=1,5 \text{ uhlik}}=600 \text{ MPa}$ and for glass $\sigma_{f=1,5 \text{ sklo}}=375 \text{ MPa}$. Here we are overrun of the both values and we must solve the fatigue life of the airplanes with MTOW 520 kg.

We supposed the postulating of fatigue life according concrete spectrum for the aircrcraft. In the aircraft there will be built-in fixing G-meter for measuring of the spectrum of load factor TL-3412 SPC and under this results will be the technical life stated.

4.6.2 The calculation of the axis of resilience

The covering transmits the torsion moment of the wing. Appropriate is this moment expressed direct to the axis of resilience EO of the wing which allows us simply to figure out the shear fliws there in duble cavity.

The position of EO we postulate with a method as in following:

Duble cavity:

$$x_e = \frac{2}{H} \cdot \left(U_{s1} - \frac{(U \cdot \Phi_3 + U_{s1} \cdot \Phi_2) \cdot \Phi_1}{\Phi_1 \cdot \Phi_2 + \Phi_2 \cdot \Phi_3 + \Phi_1 \cdot \Phi_3} \right)$$

U_{s1} -closed with centr counter

U_{s2} - the cross-section of back cavity

H- the high of spar in 25%

l1- length of the covering of front cavity

l2- length of the covering of back cavity

ts- assumed thickness of the spar

t11- assumed thickness of the covering of front cavity

t12- assumed thickness of the covering of back cavity

$$U = U_{s1} + U_{s2}$$

$$\phi_1 = \frac{L1}{t11}$$

$$\phi 2 = \frac{L2}{t12}$$

$$\phi 3 = \frac{H}{ts}$$

z	U1	U2	U	I1	I2	h	t11	t12	ts
[mm]	[mm^2]	[mm^2]	[mm^2]	[mm]	[mm]	[mm]	[mm]	[mm]	[mm]
6500	170.765	26720.16	26890.92	35.35441	1007.202	26.18106	0.45	0.45	0.6
6200	5622.978	30117.3	35740.28	224.3046	880.945	80.72993	0.45	0.45	0.6
5900	14684.94	30268.25	44953.19	405.3062	766.3763	104.2097	0.45	0.45	0.6
5754	20025.85	29517.92	49543.77	493.153	711.1478	112.2648	0.45	0.45	0.6
5600	21489.15	31117.87	52607.02	512.3699	732.3553	115.5749	0.45	0.45	0.6
5300	24484.51	34351.2	58835.72	549.8086	773.6891	122.0329	0.45	0.45	0.6
5000	27669.47	37731.21	65400.67	587.2473	815.0229	128.4909	0.45	0.45	0.6
4700	31044.01	41257.88	72301.89	624.686	856.3566	134.9489	0.45	0.45	0.6
4400	34608.15	44931.52	79539.66	662.1247	897.7868	141.407	0.45	0.45	0.6
4100	38361.87	48752.22	87114.1	699.5634	939.1871	147.865	0.45	0.45	0.6
3800	42305.19	52719.93	95025.13	737.002	980.5874	154.323	0.45	0.45	0.6
3500	46438.1	56834.65	103272.8	774.4407	1021.988	160.7811	0.45	0.45	1.2
3354	48519.21	58894.84	107414	792.6625	1042.146	163.9291	0.45	0.45	1.2
3200	48632.51	59581.79	108214.3	792.4831	1047.445	164.5535	0.45	0.45	1.2
2900	48855.47	60944.01	109799.5	792.1391	1057.802	165.7872	0.45	0.45	1.2
2600	49072.67	62304.05	111376.7	791.7903	1068.129	167.0055	0.45	0.45	1.2
2300	49291.06	63689.23	112980.3	791.4463	1078.486	168.2392	0.45	0.45	1.2
2000	49503.73	65072.08	114575.8	791.0974	1088.813	169.4576	0.45	0.45	1.8
1700	49717.56	66480.24	116197.8	790.7534	1099.17	170.6913	0.45	0.45	1.8
1400	49925.71	67885.9	117811.6	790.4046	1109.497	171.9097	0.45	0.45	1.8
1100	50134.97	69317.02	119452	790.0606	1119.854	173.1433	0.45	0.45	1.8
800	50338.6	70745.52	121084.1	789.7118	1130.167	174.3617	0.45	0.45	1.8
500	50543.28	72199.68	122743	789.3678	1140.5	175.5954	0.45	0.45	1.8
200	48157.25	81015.97	129173.2	759.7516	1388.937	176.5133	0.45	0.45	1.8
0	46552.87	84538.06	131090.9	739.9985	1561.883	176.6135	0.45	0.45	1.8

z	fi1	fi2	fi3	x	xe	xep
[mm]	[-]	[-]	[-]	[mm]	[mm]	[-]
6500	78.56535	2238.226	43.63511	-20.6671	30.66711	0.060727
6200	498.4547	1957.655	134.5499	-10.218	108.4888	0.185324
5900	900.6805	1703.058	173.6828	-3.78073	190.3223	0.285812
5754	1095.896	1580.328	187.1081	-1.04683	230.5468	0.327017
5600	1138.6	1627.456	192.6248	-0.6401	239.2518	0.329775
5300	1221.797	1719.309	203.3882	0.15593	256.2057	0.334691
5000	1304.994	1811.162	214.1515	0.962188	273.1495	0.339105
4700	1388.191	1903.015	224.9149	1.777448	290.0842	0.343092
4400	1471.388	1995.082	235.6783	2.606589	307.0051	0.346703
4100	1554.585	2087.082	246.4417	3.440284	323.9214	0.349996

3800	1637.782	2179.083	257.2051	4.279856	340.8318	0.353011
3500	1720.979	2271.084	133.9842	2.870781	359.9909	0.358022
3354	1761.472	2315.88	136.6076	3.099793	368.4002	0.359415
3200	1761.074	2327.656	137.1279	2.958541	368.3526	0.357937
2900	1760.309	2350.671	138.156	2.67852	368.2647	0.355057
2600	1759.534	2373.62	139.1713	2.403983	368.1713	0.35225
2300	1758.769	2396.636	140.1994	2.125329	368.0821	0.349456
2000	1757.994	2419.584	94.14311	1.286902	368.5526	0.347265
1700	1757.23	2442.6	94.82849	1.094193	368.3774	0.344471
1400	1756.455	2465.549	95.50536	0.905007	368.1987	0.341747
1100	1755.69	2488.564	96.19074	0.712817	368.023	0.339035
800	1754.915	2511.483	96.86762	0.523705	367.8442	0.336392
500	1754.151	2534.444	97.553	0.331219	367.6688	0.333759
200	1688.337	3086.526	98.06293	2.319588	350.6804	0.316042
0	1644.441	3470.851	98.11859	4.036851	338.9631	0.304003

4.6.3 Calculation of the shear flow, check of spar web and covering.

The covering transmits the torsion – shear flow and spar web transfer force / shear flow too.

The wings are duple cavity and shear flows we count as follow. Torsion moment causes in both cavities constant shear flows q_1 , q_2

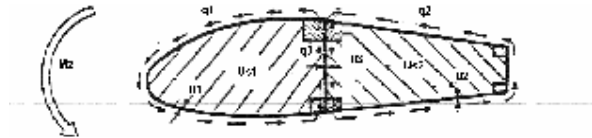

$$q_1 = \frac{Mk(E.O)}{2} \cdot \frac{Us_1 \cdot \Phi_2 + U \cdot \Phi_3}{Us_1^2 \cdot \Phi_2 + Us_2^2 \cdot \Phi_1 + U^2 \cdot \Phi_3}$$

$$q_2 = \frac{Mk(E.O)}{2} \cdot \frac{Us_2 \cdot \Phi_1 + U \cdot \Phi_3}{Us_1^2 \cdot \Phi_2 + Us_2^2 \cdot \Phi_1 + U^2 \cdot \Phi_3}$$

$$q_3 = q_1 - q_2$$

The transfer forces causes in the spar web shear flows.

For spar

$$q_y = \frac{T_y}{H_{efp}} - \text{shear flow from transfer force}$$

Spar web is a part of wing, with transfer of torsion Mk per constant shear flow. From torsion is in spar web of front spar q_3 /Nmm/.

Total shear flow q_{cstp} we obtain in this case with addition of the shear flows

$$q_{stojina} = q_y + q_3$$

The shears flows from torsion in particulare cases are evaluate in tab.

In tab., which follow, are the max. and min.values of shear flows

max

z	qk1	qk2	qk3	qy	q stojina
[m]	[N/mm]	[mm ²]	[N/mm]	[N/mm]	[N/mm]
6.500	0.00	0.00	0.00	0.00	0.00
6.200	0.43	0.54	0.11	1.78	1.79
5.900	0.87	0.93	0.06	3.98	4.01
5.754	1.06	1.07	0.02	5.18	5.19
5.600	1.24	1.26	0.01	6.64	6.65
5.300	1.59	1.59	0.00	9.52	9.52
5.000	1.89	1.87	0.03	12.39	12.38
4.700	2.17	2.11	0.06	15.19	15.17
4.400	2.41	2.33	0.09	17.92	17.90
4.100	2.63	2.52	0.12	20.57	20.54
3.800	2.82	2.68	0.16	23.14	23.10
3.500	3.01	2.82	0.22	25.61	25.57
3.354	3.09	2.88	0.24	26.79	26.74
3.200	3.26	3.05	0.24	28.45	28.41
2.900	3.59	3.38	0.24	31.72	31.67
2.600	3.90	3.70	0.24	34.99	34.95
2.300	4.20	4.01	0.23	38.27	38.23
2.000	4.50	4.31	0.22	41.54	41.50
1.700	4.78	4.61	0.20	44.79	44.76
1.400	5.07	4.93	0.18	48.03	48.01
1.100	5.36	5.24	0.15	51.25	51.23
0.8000	5.65	5.55	0.11	54.45	54.43
0.5000	5.94	5.88	0.08	57.61	57.60
0.2000	6.29	5.83	0.57	60.86	60.79
0.0000	6.73	5.86	1.06	63.21	63.08

min

z	qk1	qk2	qk3	qy	q stojina
[m]	[N/mm]	[mm ²]	[N/mm]	[N/mm]	[N/mm]
6.500	0.00	0.00	0.00	0.00	0.00
6.200	-0.41	-0.52	-0.10	-0.76	-0.87
5.900	-0.87	-0.93	-0.06	-2.16	-2.22
5.754	-1.06	-1.08	-0.02	-2.81	-2.82
5.600	-1.26	-1.28	-0.01	-3.60	-3.61
5.300	-1.64	-1.64	0.00	-5.17	-5.16
5.000	-1.99	-1.97	-0.03	-6.72	-6.69
4.700	-2.32	-2.26	-0.05	-8.24	-8.19
4.400	-2.62	-2.53	-0.08	-9.72	-9.64
4.100	-2.90	-2.78	-0.11	-11.16	-11.05
3.800	-3.16	-3.00	-0.14	-12.55	-12.41
3.500	-3.43	-3.21	-0.19	-13.90	-13.69
3.354	-3.54	-3.30	-0.21	-14.53	-14.31
3.200	-3.76	-3.52	-0.21	-15.44	-15.22
2.900	-4.18	-3.94	-0.21	-17.21	-16.99
2.600	-4.60	-4.36	-0.20	-18.99	-18.77
2.300	-5.01	-4.78	-0.19	-20.76	-20.56
2.000	-5.41	-5.19	-0.19	-22.54	-22.34
1.700	-5.80	-5.60	-0.17	-24.31	-24.12
1.400	-6.19	-6.01	-0.15	-26.06	-25.90
1.100	-6.56	-6.42	-0.12	-27.81	-27.68
0.8000	-6.93	-6.82	-0.09	-29.54	-29.44
0.5000	-7.29	-7.22	-0.06	-31.26	-31.19
0.2000	-7.70	-7.13	-0.46	-33.03	-32.52
0.0000	-8.23	-7.16	-0.87	-34.30	-33.35

The stress in the particular cross-sections we count under formula:

$$\tau = \frac{q}{t} \text{ [MPa]}$$

q shear flow
 t thickness of material in particular cross-sections

The course of the stress are in tab in following:

max

z	t1	t2	ts	τ_1	τ_2	τ_s	f1	f2	fs
[m]	[mm]	[mm]	[mm]	[mm]	[mm]	[mm]	[]	[]	[]
6.5000	0.45	0.45	0.6	0.00	0.00	0.00			
6.2000	0.45	0.45	0.6	0.96	1.20	2.99	68.81	54.91	22.10
5.9000	0.45	0.45	0.6	1.94	2.08	6.68	33.97	31.79	9.88
5.7540	0.45	0.45	0.6	2.35	2.39	8.64	28.12	27.65	7.64
5.6000	0.45	0.45	0.6	2.77	2.79	11.08	23.86	23.62	5.96
5.3000	0.45	0.45	0.6	3.53	3.52	15.87	18.68	18.73	4.16
5.0000	0.45	0.45	0.6	4.21	4.15	20.63	15.67	15.89	3.20
4.7000	0.45	0.45	0.6	4.81	4.70	25.29	13.71	14.05	2.61
4.4000	0.45	0.45	0.6	5.35	5.17	29.83	12.33	12.76	2.21
4.1000	0.45	0.45	0.6	5.84	5.59	34.23	11.31	11.81	1.93
3.8000	0.45	0.45	1.2	6.27	5.96	19.25	10.52	11.08	3.43
3.5000	0.45	0.45	1.2	6.70	6.27	21.31	9.86	10.53	3.10
3.3540	0.45	0.45	1.2	6.87	6.41	22.28	9.60	10.30	2.96
3.2000	0.45	0.45	1.2	7.25	6.78	23.67	9.10	9.73	2.79
2.9000	0.45	0.45	1.2	7.97	7.51	26.39	8.28	8.79	2.50
2.6000	0.45	0.45	1.2	8.67	8.22	29.13	7.61	8.03	2.27
2.3000	0.45	0.45	1.2	9.34	8.91	31.86	7.07	7.41	2.07
2.0000	0.45	0.45	1.8	10.00	9.58	23.06	6.60	6.89	2.86
1.7000	0.45	0.45	1.8	10.62	10.25	24.87	6.21	6.44	2.65
1.4000	0.45	0.45	1.8	11.28	10.95	26.67	5.85	6.03	2.47
1.1000	0.45	0.45	1.8	11.92	11.65	28.46	5.54	5.67	2.32
0.8000	0.45	0.45	1.8	12.55	12.34	30.24	5.26	5.35	2.18
0.5000	1.05	1.05	1.8	5.66	5.60	32.00	11.66	11.79	2.06
						fmin	5.26	5.35	1.93

min

z	t1	t2	ts	τ_1	τ_2	τ_s	f1	f2	fs
[m]	[mm]	[mm]	[mm]	[mm]	[mm]	[mm]	[]	[]	[]
6.5000	0.45	0.45	0.6	0.00	0.00	0.00			
6.2000	0.45	0.45	0.6	-0.92	-1.15	-1.45	72.01	57.47	45.67
5.9000	0.45	0.45	0.6	-1.92	-2.06	-3.69	34.29	32.09	17.86
5.7540	0.45	0.45	0.6	-2.36	-2.40	-4.71	28.02	27.55	14.02
5.6000	0.45	0.45	0.6	-2.81	-2.83	-6.02	23.52	23.29	10.96
5.3000	0.45	0.45	0.6	-3.65	-3.64	-8.60	18.07	18.11	7.67
5.0000	0.45	0.45	0.6	-4.43	-4.37	-11.15	14.90	15.10	5.92
4.7000	0.45	0.45	0.6	-5.15	-5.02	-13.65	12.82	13.14	4.84
4.4000	0.45	0.45	0.6	-5.81	-5.62	-16.07	11.35	11.74	4.11
4.1000	0.45	0.45	0.6	-6.44	-6.17	-18.41	10.25	10.70	3.59
3.8000	0.45	0.45	1.2	-7.03	-6.67	-10.34	9.39	9.89	6.38
3.5000	0.45	0.45	1.2	-7.61	-7.12	-11.41	8.67	9.26	5.78
3.3540	0.45	0.45	1.2	-7.87	-7.33	-11.93	8.39	9.00	5.53
3.2000	0.45	0.45	1.2	-8.35	-7.81	-12.68	7.90	8.45	5.21
2.9000	0.45	0.45	1.2	-9.30	-8.76	-14.16	7.10	7.54	4.66
2.6000	0.45	0.45	1.2	-10.22	-9.69	-15.64	6.46	6.81	4.22
2.3000	0.45	0.45	1.2	-11.13	-10.62	-17.13	5.93	6.22	3.85
2.0000	0.45	0.45	1.8	-12.03	-11.53	-12.41	5.49	5.72	5.32
1.7000	0.45	0.45	1.8	-12.90	-12.45	-13.40	5.12	5.30	4.92
1.4000	0.45	0.45	1.8	-13.75	-13.36	-14.39	4.80	4.94	4.59
1.1000	0.45	0.45	1.8	-14.58	-14.26	-15.38	4.53	4.63	4.29
0.8000	0.45	0.45	1.8	-15.40	-15.15	-16.36	4.28	4.36	4.04
0.5000	1.05	1.05	1.8	-6.95	-6.87	-17.33	9.50	9.60	3.81
						fmin	4.28	4.36	3.59

We have the disturbance of stability of the sandwich and this is why we must postulate comparative critical stress.

Under our experiences it is dimpling, local disturbance which leads to the disturbance of core and the layers of surfaces edged.

At this kind of disturbance it is importuned the E-module of core and foam.

From calculations and tests at Institute of aerospace engineering TU Brno we postulated the critical stress $\tau_{kr} = 66$ MPa.

Min safety of spar web $f_s = 1.93$ comply even if we implicate the temperature influence. This value is pessimistic because the test gave the higher value.

See the report – Stress test of root part of the composite wing at firm VANESSA air.

4.6.4 Root rib and field joint wing = fuselage.

The wing is connected at either side with two knuckle joints which impart the transfer force and the force couple from torsion moment between the wing and fuselage. The scheme of this connection is in following picture:

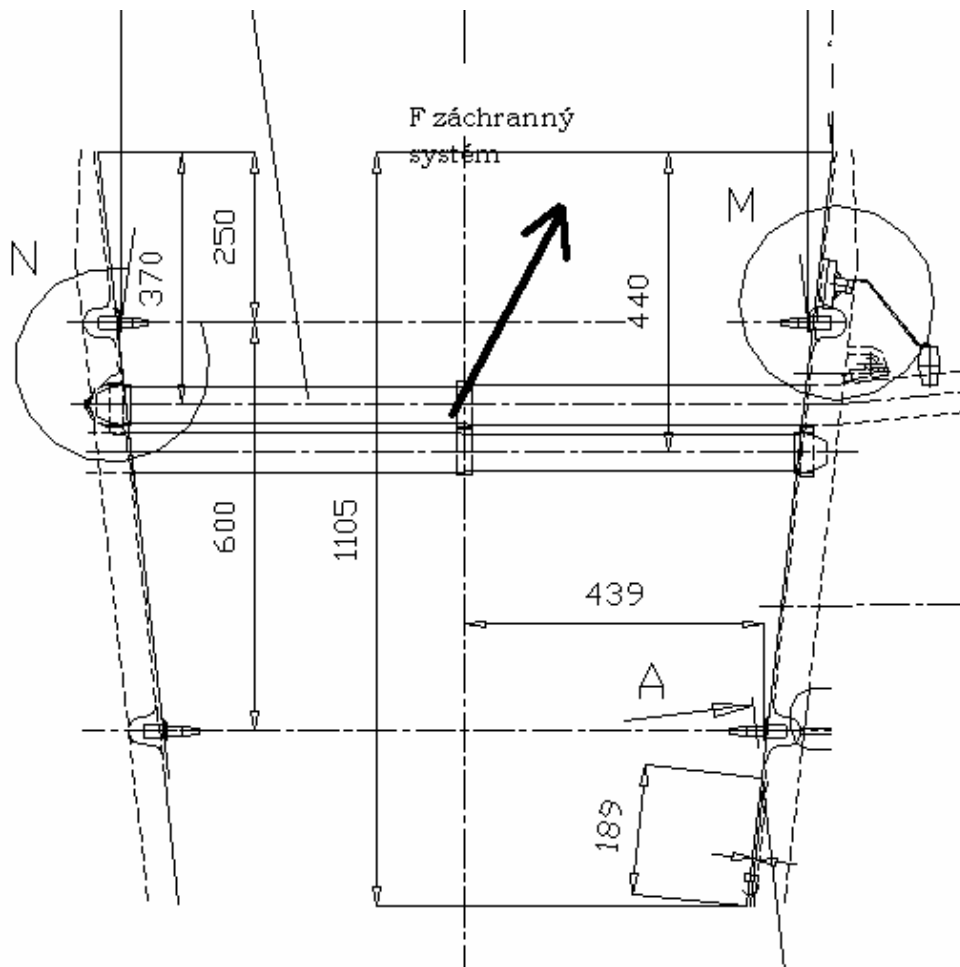

Max load on one pin at safety against failure $f=1$ is $R_{1c} = 9811$ N, this load is taken from reaction of fuselage – test jig for the load case No.1 – max. positive load factor at gust. This reaction follows from static loading of fuselage, where the fuselage we interpret as a beam with two supports. It doesn't take into account the absorb characteristic and this is why the load is at safety side.

The proper suspensor on fuselage is created with embedded housings

Opposite parts on root rib are the pins, embedded in wing, the scheme is on picture:

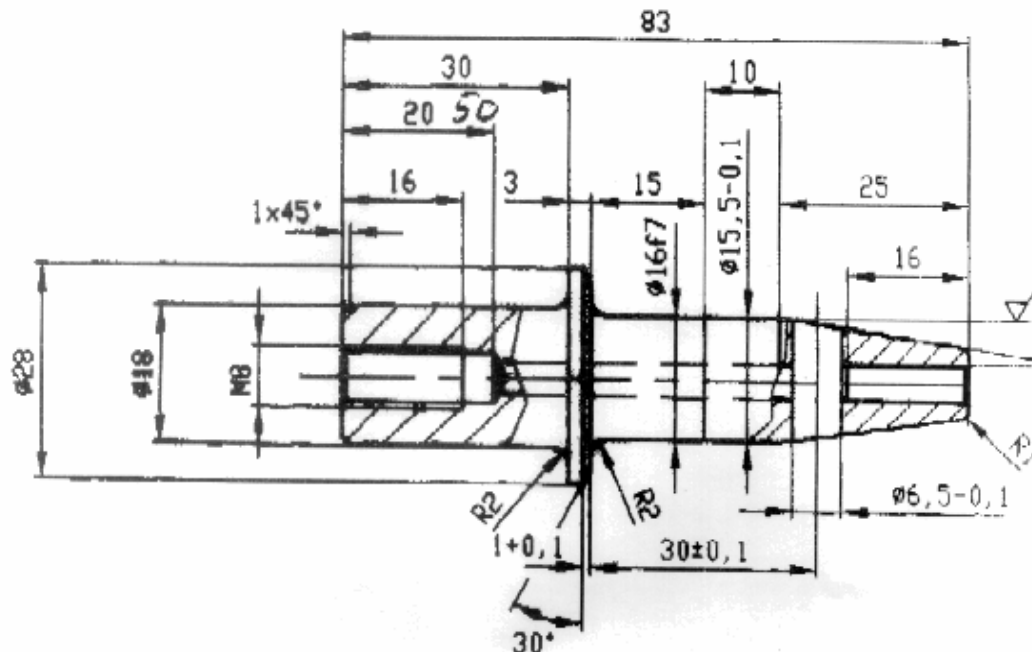

We check the seating this steel parts in the laminat on wing and fuselage up to compression stress.

In the fuselage is the bushing gripped in epoxy-laminat of thickness $t = 4.05$ mm , $\sigma_{Dov.} = 140$ MPa at operating load. The force is in to laminat led on diameter of bushing $d = 23.5$ mm (see.the drawing). The value of stress in compressing is then:

$$\sigma_{otlačení} = \frac{Rlc}{t \cdot d} = \frac{9811}{4.05 \cdot 23.5} = 103 \text{ MPa} < \sigma_{Dov.} = 140 \text{ MPa} , \text{comply}$$

In the root rib is the pin $d = 18$ mm gripped in laminat $t = 4.5$ mm

$$\sigma_{otlačení} = \frac{Rlc}{t \cdot d} = \frac{9811}{4.5 \cdot 18} = 121 \text{ MPa} < \sigma_{Dov.} = 140 \text{ MPa} , \text{comply}$$

Futher place, which is necessary to check on compression stress is the seating of the end of wing spar (cantilever) into the root rib of next wing. Here is transfered the reaction from bending moment, its value is:

$$R = \frac{M_{o \max}}{r} \text{ kde}$$

$M_{o \max}$ is max. bending moment in the place of root rib , in case at gust 15 m/s $M_{o \max} = 20726$ Nm and r is spacing between root ribs $r = 1.3$ m

$$R = \frac{26385}{1.1} = 23986 \text{ N}$$

This force is into root ribs led with the metal bushing $d = 65$ mm into laminat $t = 3.0$ mm.

$$\sigma_{otlačení} = \frac{R}{t \cdot d} = \frac{23986}{3.0 \cdot 65} = 123 \text{ MPa} < \sigma_{Dov.} = 140 \text{ MPa} , \text{comply}$$

4.6.5 Flapperon and suspension of flapperon.

Dimensioning of this parts was mostly from technological reasons, the thicknesses of covering were limit with handling forces and at flapperon from reason of its drive at the end and of criterion of stability . This was solved on model MKP. The load was proved with test.

5. Summary.

By reason of assumptioned inaccuratings of basic calculations, for ex. To include of influences from curvatore of sandwich panels, combination of load for some parts-root ribs, the model MPK was created, which is archived at Vanessa Air, but first of all was the prove led consistently under tests. The comparing of courses in the first part of report corresponds with operating values. Operating value of test was obtained thru divide of 2,25 coefficient.

With exact comparing of the courses we can find, that with test was proved the value of safety $f' = 2,07$ for spar web and $f'' = 2,52$ for prove of bending moment.

The airplane UFM-13 complpy with strength demands of JAR-VLA regulations with the MTOW 520 kg.